

PORTABLE HYDRAULIC POWER UNIT MODEL HT100EV

The HT100EV power unit is driven by a 100HP 460 V, 3Ø, 60 H TEFC electric motor for use where electric power is available. It is designed to drive several of our pumps or other hydraulic equipment and tools.

Control Panel:
Nema 3R, 100HP, Combination Circuit, Breaker, Start/Stop Push button, 120 VAC, 200 VA, Control Transformer, Pilot Light, Overload Reset (not shown in photo)



FEATURES

- Skid Frame Chassis with Fork Slots & Drip Pan
- Single Point Lifting Bracket
- Tandam Gear Hydraulic Pumps w/ manifold & Control Valve
- Case Drain Oil Cooler, Motor Fan Assisted
- Tethered Pendant for Raise/ Lower Shop winch control
- Spin-On Return Filter w/ Dust Indicator
- Tank Top Filler/ Strainer
- System Relief Valve
- Pressure Relief
- Liquid Filled Pressure Gauge
- Fluid Level/ Temperature Gauge
- Nema 3 Control Panel

OPTIONS

- Low Oil / High Temp Shutdown
- Water Cooled Heat Exchanger

A1213

Model HT100EV Overall Dimensions

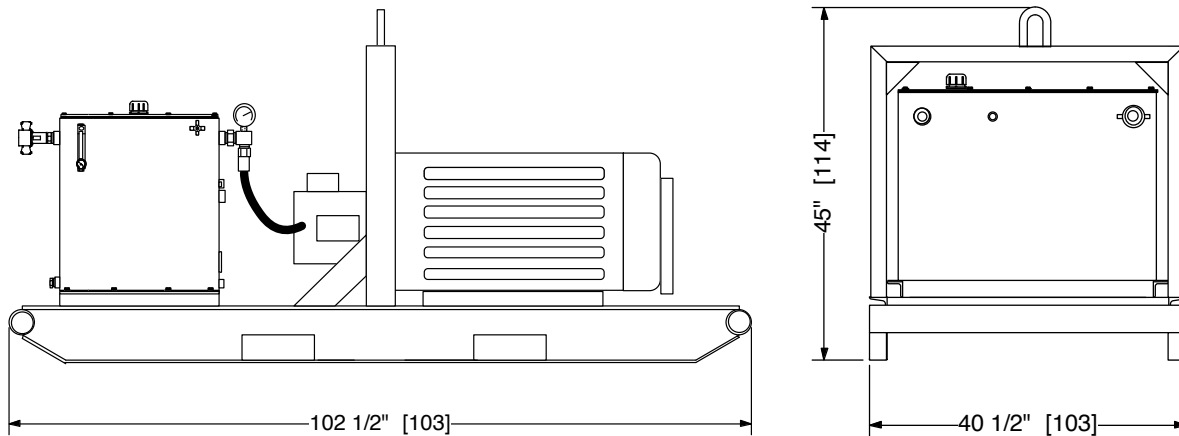

SPECIFICATIONS

MOTOR:..... 100 HP 230/460 Volts, 3 Phase, 60 Hz, TEFC
SPEED:..... 1780 RPM
FULL LOAD AMPS:..... 248/124
HYDRAULIC OUTPUT:..... Total, Max. 40 GPM (151 LPM)
OPERATING PRESSURE:..... Maximum 3000 PSI (206 Bar)
HOSE PORT SIZE:..... 3/4"
HYDRAULIC OIL:..... SAE 10W or 20W (ISO 32 or 46) Type AW
..... also: Biodegradable oil (Consult Factory)
OIL FILTRATION:..... 10 Micron (Standard)
OIL RESERVOIR CAPACITY:..... 50 U.S. Gallons (284 Liters)
DIMENSIONS:.... H 45" (114 cm) x W 40-1/2" (103 cm) x L 102-1/2" (260 cm)*
WEIGHT (Dry):..... 1540 lbs. (698 kg)*

* Approximate weight and dimensions

Since we are constantly working to improve our products, specifications are subject to change without notice.



167 Stock Street, Nesquehoning, PA 18240 Phone: 570-645-3779 Fax: 570-645-4061

Website: www.hydra-tech.com

E-Mail: htpump@hydra-tech.com