



PORTABLE HYDRAULIC POWER UNIT

MODEL HT11DXR

This compact and rugged diesel power unit features an extended run fuel tank, extra oil cooling and easy handling. Great for continuous duty applications powering our pumps or other hydraulic equipment using the variable speed throttle to control hydraulic output.

FEATURES

- Kubota air-cooled Diesel Engine with Electric Start
- Roll Cage Frame with Single Point Lifting Eye
- Gear-Type Hydraulic Pump
- Spin-On Return Filter W/ Indicator
- Variable Speed Throttle Controls Hydraulic Output
- Hydraulic Oil Cooler
- Tank Top Filler/ Strainer
- HTMA Quick - Disconnect Couplings
- System Relief Valve
- Made in USA
- Liquid Filled Pressure Gauge
- Fluid Level/ Temperature Gauge
- Fuel Level Gauge
- Wheel Kit

OPTIONS

- Other Flow and Pressure Combinations

A0116



167 Stock Street, Nesquehoning, PA 18240 Phone: 570-645-3779 Fax: 570-645-4061

Website: www.hydra-tech.com

E-Mail: htpump@hydra-tech.com

Model HT11DXR Overall Dimensions

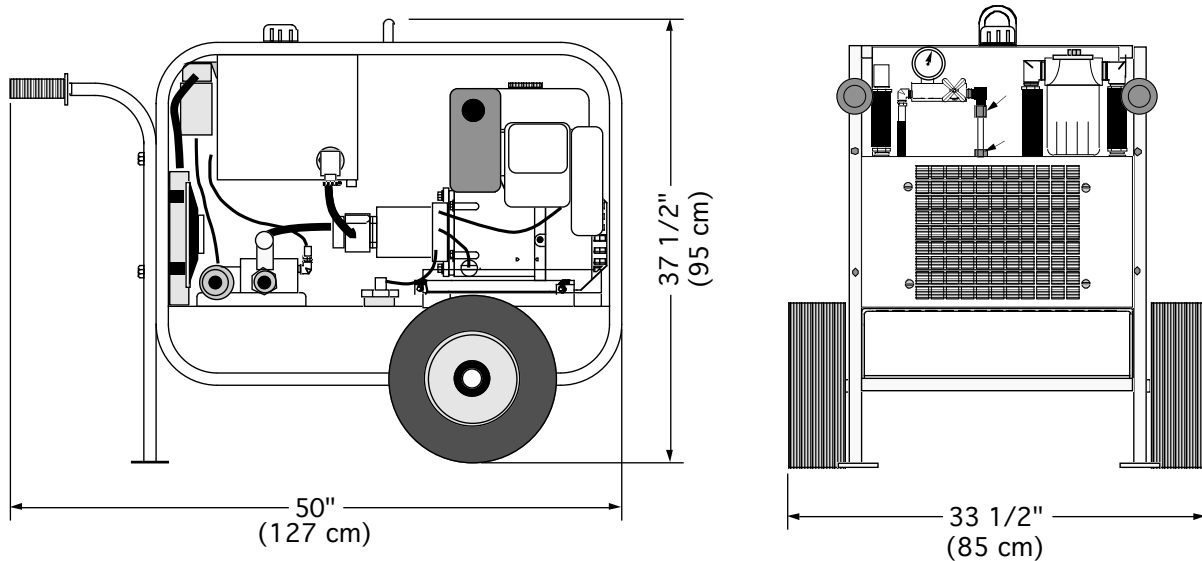

SPECIFICATIONS

ENGINE:	Kubota OC95-E4
HORSE POWER:	9.4 @ 3600 RPM
HYDRAULIC OUTPUT:	Variable, Max 6 GPM (23 LPM)
OPERATING PRESSURE:	Maximum 2000 PSI (143 Bar)
HOSE PORT SIZE:	1/2" or 3/4" NPT
HYDRAULIC OIL:	SAE 10W or 20W Type AW also: Dexron ATF or Biodegradable oil
OIL FILTRATION:	10 Micron (Standard)
OIL RESERVOIR CAPACITY:	8 U.S. Gallons (30 Liters)
FUEL TANK CAPACITY:	15 U.S. Gallons (57 Liters)
FUEL CONSUMPTION:	Approx. .63 U.S. Gal/Hr (2.39 Liters/Hr)
DIMENSIONS:	H 37 1/2" (95 cm) x W 33 1/2" (85 cm) x L 50" (127 cm)
WEIGHT (Dry):	400 lbs. (181 kg)

* For Flows and Pressures Other Than Standard, Consult Factory

Since we are constantly working to improve our products, specifications are subject to change without notice.



167 Stock Street, Nesquehoning, PA 18240 Phone: 570-645-3779 Fax: 570-645-4061

Website: www.hydra-tech.com

E-Mail: htpump@hydra-tech.com