

PORTABLE HYDRAULIC POWER UNIT

MODEL HT6D

This portable diesel power pack is ideal for driving our 2" pumps and slim-line borehole pump. It also can provide hydraulic power to run many other hydraulic tools. Two models are available with flows of 3 GPM @ 2500 PSI or 4.5 GPM @ 1800 PSI.



Unit shown with optional wheel kit

FEATURE

- Yanmar Tier 4 Final air-cooled Diesel Engine
- Roll Cage Frame with Single Point Lifting Eye
- Gear-Type Hydraulic Pump
- Spin-On Return Filter W/ Indicator
- Variable Speed Throttle Controls Hydraulic Output
- Hydraulic Oil Cooler
- Tank Top Filler/ Strainer
- HTMA Quick - Disconnect Couplings
- System Relief Valve
- Made in USA
- Liquid Filled Pressure Gauge
- Fluid Level/ Temperature Gauge
- Sized for Many Small Hydraulic Tools

OPTIONS

- Wheel Kit
- Electric Start
- Other Flow and Pressure Combinations

A0116

Model HT6D Overall Dimensions

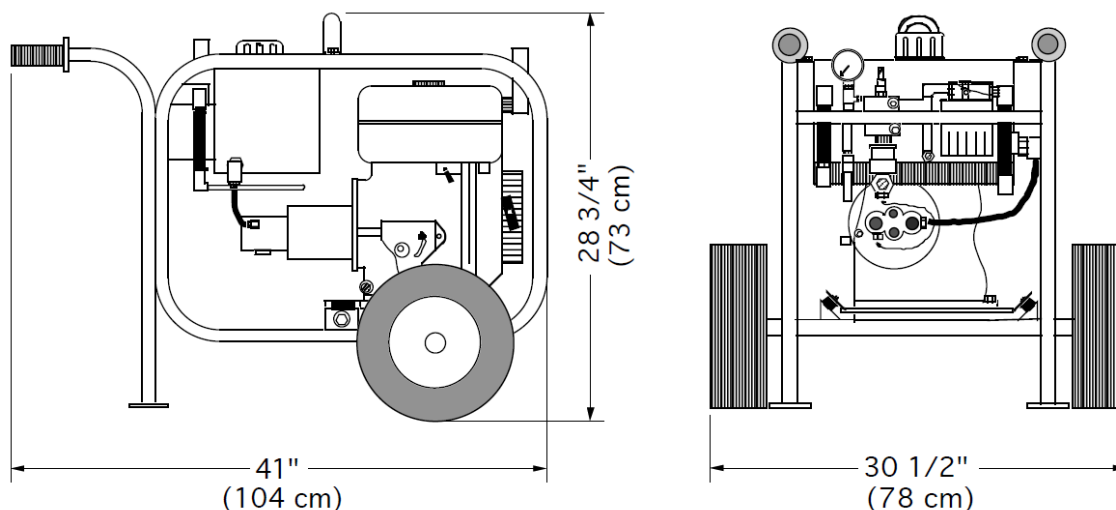

SPECIFICATIONS

ENGINE:..... Yanmar L70V Diesel (Tier 4 Final)
HORSE POWER:..... 6 @ 3600 RPM
HYDRAULIC OUTPUT:..... 3 GPM (11 LPM) @ 2500 PSI (170 Bar)
or:.....4.5 GPM (17 LPM) @ 1800 PSI (122 Bar)
HOSE PORT SIZE:.....1/2" NPT
HYDRAULIC OIL:.....SAE 10W or 20W Type AW
also...Dexron ATF or Biodegradable Oil
OIL FILTRATION:.....10 Micron (Standard)
OIL RESERVOIR CAPACITY:..... 4 U.S. Gallons (15.1 Liters)
FUEL TANK CAPACITY:..... .7 U.S. Gallons (2.7 Liters)
FUEL CONSUMPTION:..... Approx. .5 U.S. Gal/Hr (2 Liters/Hr)
DIMENSIONS:..... H 25" (63.5 cm) x W 20" (51 cm) x L 30" (76 cm)
w/ Wheel Kit: H 28 3/4" (73 cm) x W 30 1/2" (78 cm) x L 41" (104 cm)
WEIGHT (Dry):.....192 lbs. (87 kg)

* For Flows and Pressures Other Than Standard, Consult Factory

Since we are constantly working to improve our products, specifications are subject to change without notice.



167 Stock Street, Nesquehoning, PA 18240 Phone: 570-645-3779 Fax: 570-645-4061

Website: www.hydra-tech.com

E-Mail: htpump@hydra-tech.com