

6" HYDRAULIC SUBMERSIBLE SAND/ SLURRY PUMP *with Agitator*

MODEL

S6CSL

6" (15 cm) Discharge

The S6CSL pump is designed to use in applications requiring settled solids to be put into suspension and pumped with the discharge water. Primary applications include de-silting waterways. Other jobs may include filling sand bags to prevent beach erosion, tank and digester cleaning or pumping sediment from caissons. Durable pump for clearing cellars during drilling operations.



FEATURES

- Hardened Alloy Wear Parts
- Built-in Agitator for stirring up solids
- Oil Lubricated Seals (can run dry)
- Variable Speed hydraulic drive
- Small Size allows pump to fit through a 22 inch opening
- Safe Hydraulic Drive can be used where electric power is hazardous or impractical
- Dependable gear type hydraulic motor
- Operates with our HT50 to HT75 power units or other hydraulic power sources capable of flows to 28 GPM
- Fully Hardened Model Available

SPECIFICATIONS

WEIGHT:	528 lbs. (240 kg)
HEIGHT:	39" (99 cm)
WIDTH (@ widest point):	21 1/4" (54 cm)
DISCHARGE:	6" NPT
SOLIDS HANDLING:	1 1/2" (4 cm)
HOSE PORTS:	1" NPT (F)
VOLUTE*:	Hardened Ductile Iron
IMPELLER:	High Chrome Alloy
WEAR PLATE:	High Chrome Alloy
AGITATOR:	High Chrome Alloy
SHAFT:	Stainless Steel
SHAFT SEALS: (upper):	Silicon Carbide
(Lower):	Silicon Carbide
HYDRAULIC OIL:	214-320 s.s.u. @ 100°F (64°C)
INPUT FLOW:	Max 28 GPM (106 LPM)
OPERATING PRESSURE:	Max 3000 PSI (204 Bar)
POWER SOURCE:	Any Open Center Hydraulic System

* Optional NI-Hard volute available for highly abrasive applications

D0516

Specifications are subject to change without notice

Model S6CSL Overall Dimensions

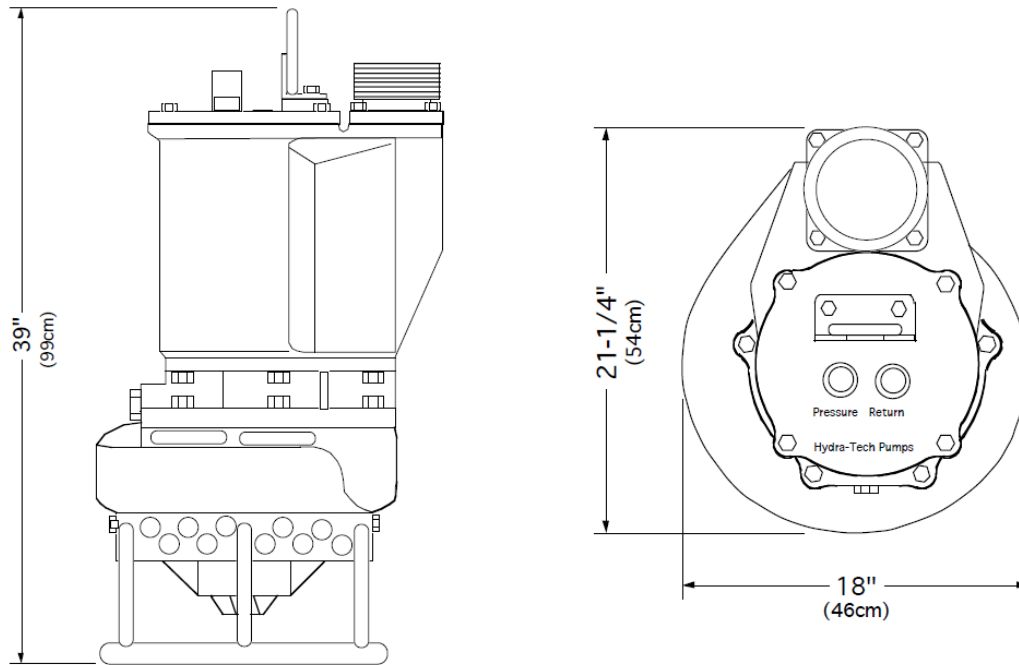

S6CSL Typical Performance

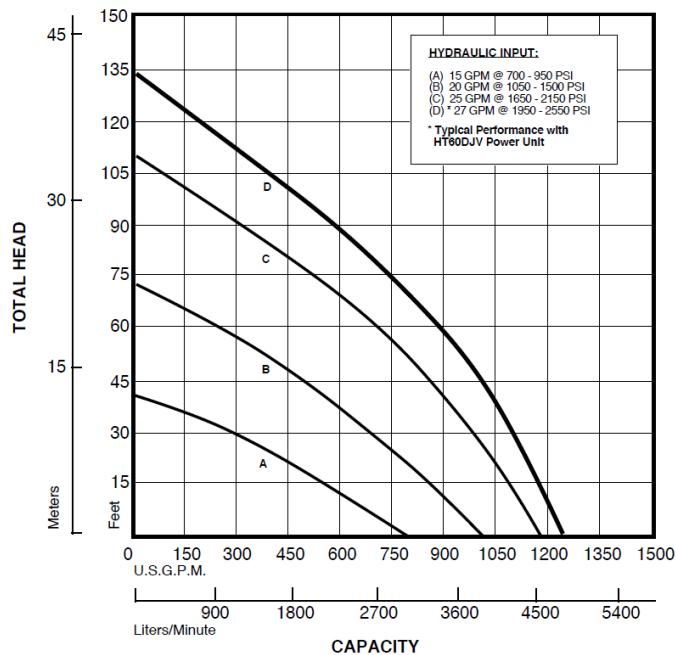

Curves are based on pumping water at 60°F. For performance curves other than shown above, consult factory.

