

10" HYDRAULIC SUBMERSIBLE HIGH PERFORMANCE SOLIDS HANDLING PUMP MODELS

S6250

10" (25 cm) Discharge

The S6250 is a Solids Handling Effluent Pump for use on jobs such as waste treatment, sewer by-pass, barge transfer, municipal lift stations and tank pumping. Heads to 190 feet and flows to 5000 GPM.



FEATURES

- Balanced High Efficiency Two Vane Closed Channel Impeller
- Will pass 4" (10 cm) semi-solids
- Variable Speed hydraulic drive provides a wide range of performance
- Oil Lubricated Seals (can run dry)
- High Efficiency Balanced Vane hydraulic motor
- Can be bolted directly into a pipeline or used as a booster pump
- Safe Hydraulic Drive can be used where electric power is hazardous or impractical
- Operates with our HT100 to HT200 power units or other hydraulic power sources capable of flows of 50 - 90 GPM

SPECIFICATIONS

WEIGHT:	739 lbs. (336 kg)
HEIGHT:	43" (109 cm)
WIDTH (@ widest point):	32" (81 cm)
DISCHARGE:	10", 125# ASA Flange
INLET:	10", 125# ASA Flange
SOLIDS HANDLING:	5" (13 cm)
HOSE PORTS:	1-1/4" Code 61 Flange or 1-1/2" NPT (F)
PUMP BODY:	Ductile Iron
IMPELLER:	Ductile Iron
WEAR RING:	Ductile Iron
SHAFT:	17-4 PH Stainless Steel
SHAFT SEAL:	Silicon Carbide
ELASTOMERS:	Buna N (Std)
HYDRAULIC OIL:	214-320 s.s.u. @ 100°F (64°C)
INPUT FLOW:	Max 90 GPM (340 LPM)
OPERATING PRESSURE:	Max 3000 PSI (204 Bar)
POWER SOURCE:	Any Open Center Hydraulic System

D0516

Specifications are subject to change without notice

Model S6250 Overall Dimensions

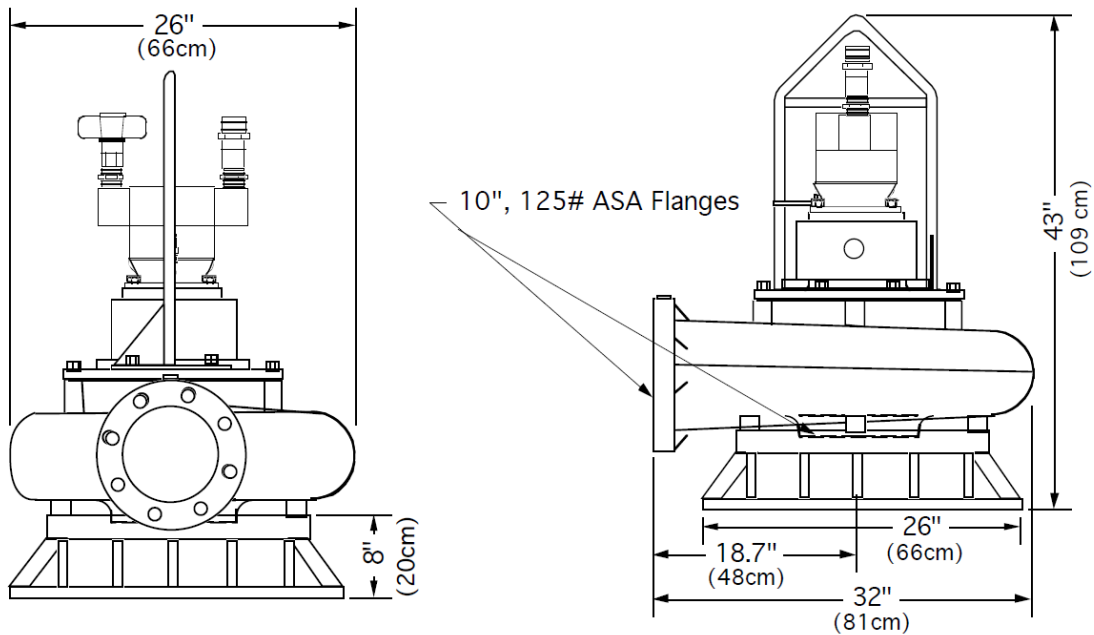

S6250 Typical Performance

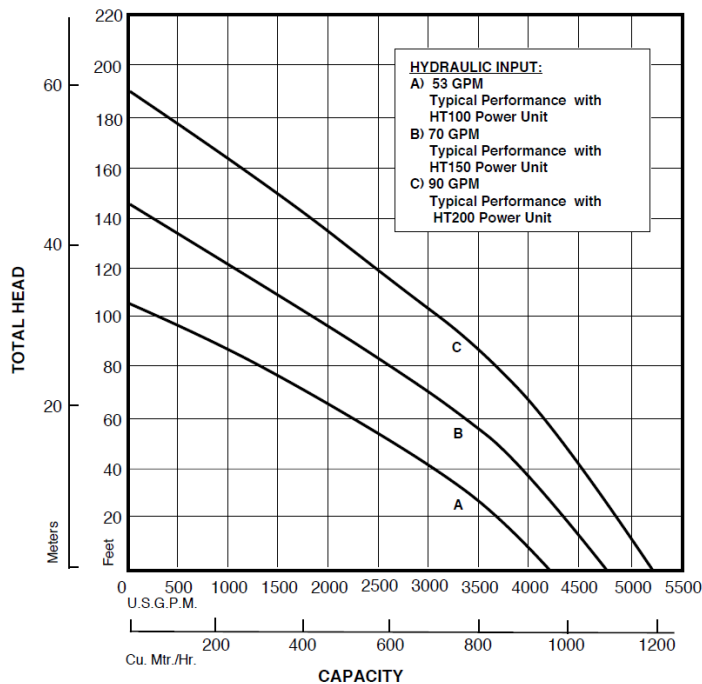

Curves are based on pumping water at 60°F. For performance curves other than shown above, consult factory.

