

12" HYDRAULIC SUBMERSIBLE AXIAL FLOW HIGH VOLUME PUMP

MODELS

S12M

12" (30 cm) Discharge

The S12M is designed for pumping high volumes of water at low to medium heads. This pump is great for lake draining, flood control, drydock, foundation and cofferdam de-watering. Also use as a water supply pump for mobile fire suppression systems.



FEATURES

- High Volume Axial Flow design
- High Efficiency mixed flow impeller
- Small Overall Size allows for use in tight spaces
- Variable Speed hydraulic drive
- Oil Lubricated Seals (can run dry)
- Dependable gear type hydraulic motor
- Safe Hydraulic Drive can be used where electric power is hazardous or impractical
- Operates with our HT35 to HT60 power units or other hydraulic power sources capable of flows of 20 - 26 GPM
- Custom configurations to fit smaller openings

SPECIFICATIONS

WEIGHT:..... 385 lbs. (174 kg)
 HEIGHT:..... 41" (104 cm)
 DIAMETER (@ widest point):..... 27 1/2" (70 cm)
 DISCHARGE:.....12.75" O.D. Pipe or Flange
 SOLIDS HANDLING:..... 1" (2.5 cm)
 HOSE PORTS:.....1" NPT
 HYDRAULIC COUPLINGS:..... 1" Wing Nut Style
 PUMP BODY:..... Cast Iron
 IMPELLER:..... Bronze
 SHAFT:..... Stainless Steel
 SHAFT SEALS:..... Carbon/Ceramic (Std)
 ELASTOMERS:..... Buna N (Std)
 HYDRAULIC OIL:..... 214-320 s.s.u. @ 100°F (64°C)
 INPUT FLOW:..... Max. 26 GPM (98 LPM)
 INPUT PRESSURE:.. Max. Cont. 2900 PSI (197 Bar)
 POWER SOURCE:.. Any Open Center Hydraulic System

D0516

Specifications are subject to change without notice

Model S12M Overall Dimensions

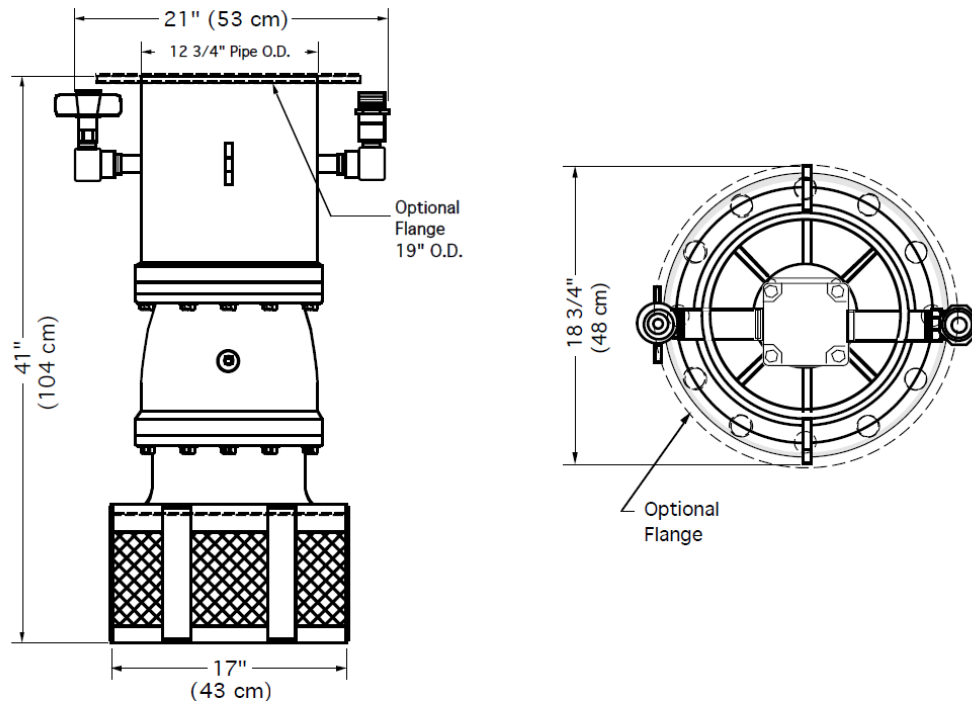

S12M Typical Performance

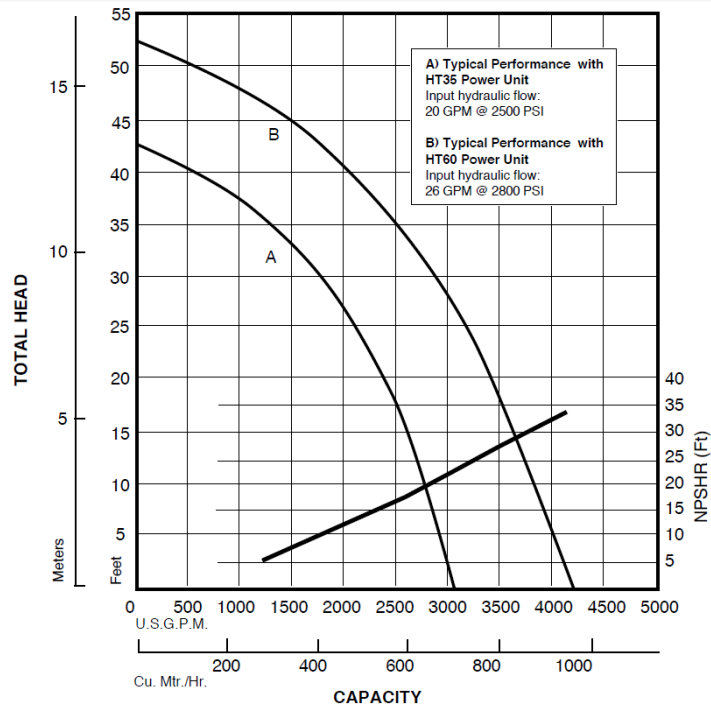

Curves are based on pumping water at 60°F. For performance curves other than shown above, consult factory.

