

3" HYDRAULIC SUBMERSIBLE SAND/ SLURRY PUMP *with Agitator*

MODEL

S3CSL

3" (8 cm) Discharge

The S3CSL pump is designed for use in applications requiring settled solids to be put into suspension and pumped with the discharge water. Primary applications include de-silting ponds, lakes and streams. Other jobs may include filling sand bags to prevent beach erosion, tank and digester cleaning or pumping residue from rail tank cars or barges, often used for slip dredging at marinas.



FEATURES

- Hardened Alloy Wear Parts
- Built-in Agitator for stirring up solids
- Oil Lubricated Seals (can run dry)
- Variable Speed hydraulic drive
- Small Size allows pump to fit through a 17 inch opening
- Safe Hydraulic Drive can be used where electric power is hazardous or impractical
- Dependable gear type hydraulic motor
- Operates with our HT10 to HT20 power units or other hydraulic power sources capable of flows to 9 GPM

SPECIFICATIONS

WEIGHT:	231 lbs. (105 kg)
HEIGHT:	30 1/4" (77 cm)
WIDTH (@ widest point):	16 1/4" (41 cm)
DISCHARGE:	3" NPT
SOLIDS HANDLING:	1 1/2" (4cm)
HOSE PORTS:	1/2" and 3/4" NPT (F)
VOLUTE*:	Hardened Ductile Iron
IMPELLER:	High Chrome Alloy
WEAR PLATE:	High Chrome Alloy
AGITATOR:	High Chrome Alloy
SHAFT:	304 Stainless Steel
SHAFT SEALS: (upper):	Carbon/Ceramic
(Lower):	Silicon Carbide
HYDRAULIC OIL:	214-320 s.s.u. @ 100°F (64°C)
INPUT FLOW:	Max 9 GPM (34 LPM)
OPERATING PRESSURE:	Max 2500 PSI (170 Bar)
POWER SOURCE:	Any Open Center Hydraulic System

* Optional NI-Hard volute available for highly abrasive applications

D0516

Specifications are subject to change without notice

Model S3CSL Overall Dimensions

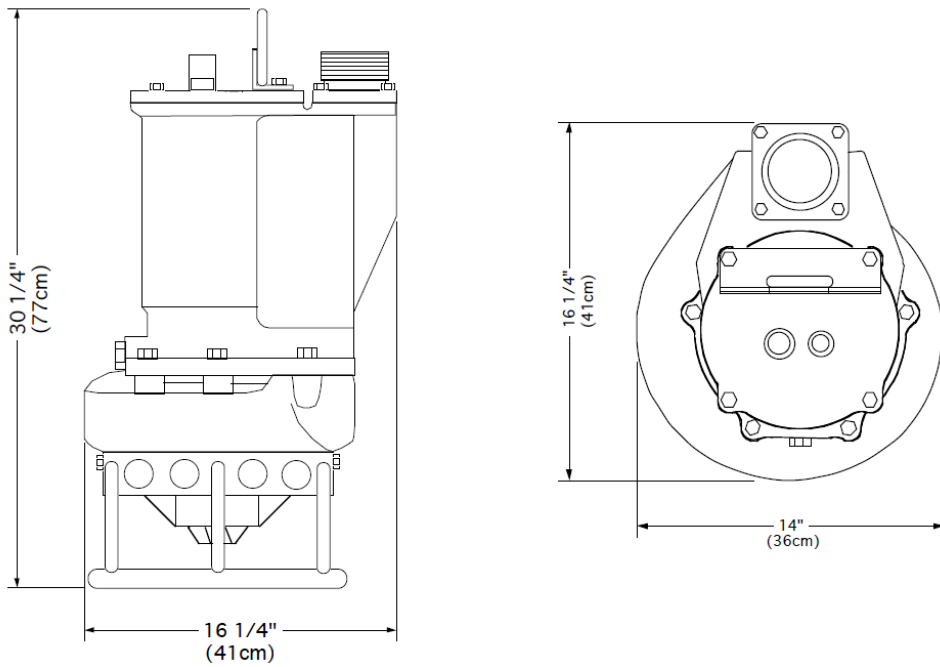

S3CSL Typical Performance

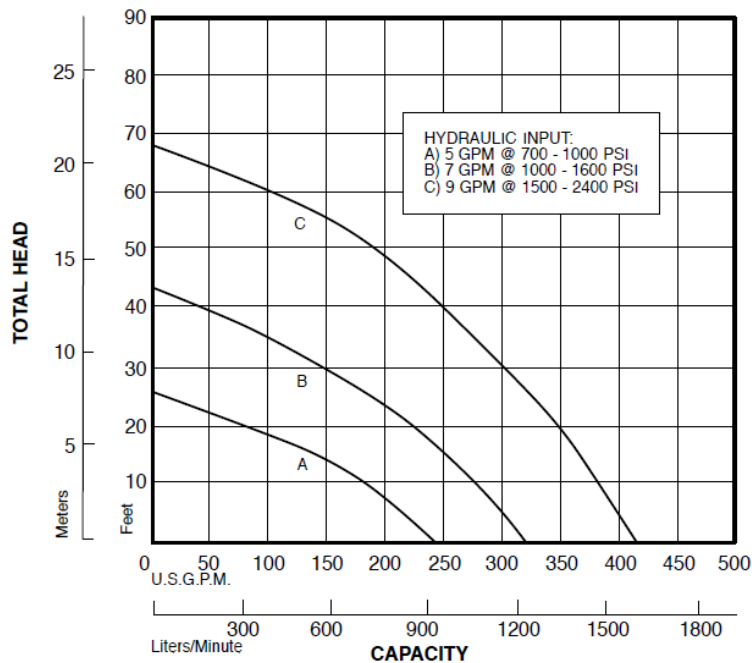

Curves are based on pumping water at 60°F. For performance curves other than shown above, consult factory.

