

PORTABLE HYDRAULIC POWER

UNIT MODEL HT74DVP



This popular unit features a Perkins diesel engine and variable piston hydraulic pump for maximum versatility and enhanced performance when driving submersible pumps or other hydraulic equipment.

FEATURES

- Highway Trailer Chassis with built-in Extended Run Fuel Tank, Independent Suspension, D.O.T. Brakes and Lighting
- Single Point Lifting Bracket, Tie Downs and Stabilizer Jacks for Transport and Setup
- Digital Engine Control Panel with Auto-Start Capability
- Shutdowns for Low Hydraulic Oil Level and High Hydraulic Oil Temp
- Variable Piston Hydraulic Pump
- Efficient Hydraulic Oil Cooler
- Tank Top Filler/ Strainer
- Spin-On Return Filter
- System Relief Valve
- Pressure Control Valve
- Liquid Filled Pressure Gauge

OPTIONS

- Skid Frame Options
- Other Flow and Pressure Combinations
- Auto Start Panel

A0116

Model HT74DVP Overall Dimensions

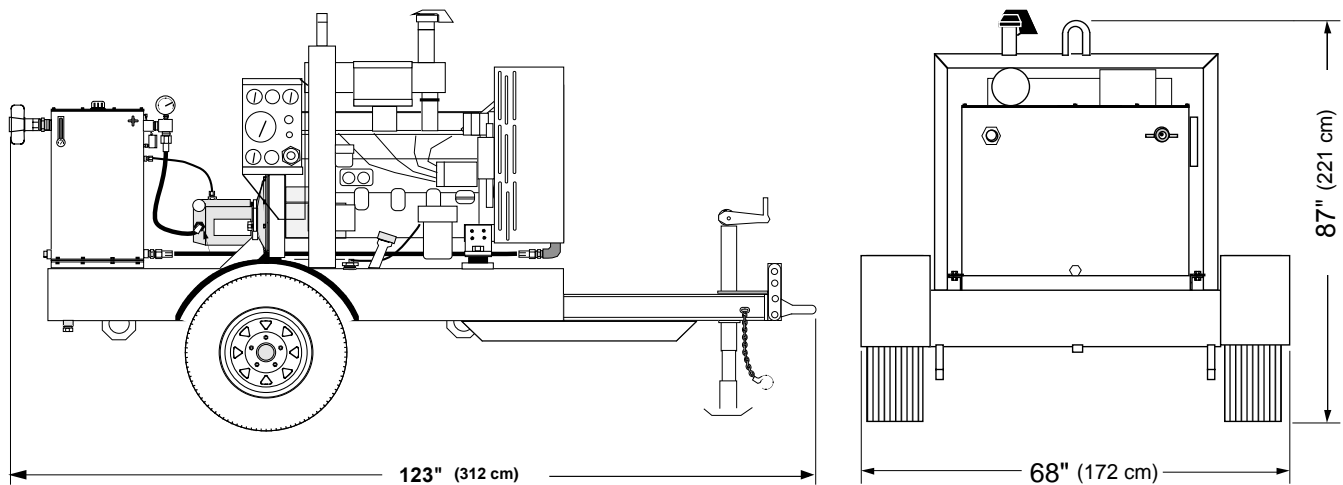

Unit shown here is not the actual unit but dimensions are accurate

SPECIFICATIONS

ENGINE:.....Perkins 854F-E347 diesel (EPA Tier 4 Final)
HORSEPOWER:.....74 @ 2200 RPM
HYDRAULIC OUTPUT*:.....Variable, Max. 28 GPM (189 LPM)
OPERATING PRESSURE*:.....Maximum 2900 PSI (199 Bar)
HOSE PORT SIZE:.....1" NPT Pressure, 1" Return
.....1/2" NPT port (Optional Case Drain)
HYDRAULIC OIL:.....AW Biodegradable oil
OIL FILTRATION:.....10 Micron (Standard)
OIL RESERVOIR CAPACITY:.....50 U.S. Gallons (189 Liters)
FUEL TANK CAPACITY:.....82 U.S. Gallons (310 Liters)
FUEL CONSUMPTION:.....Approx. 4.08 U.S. Gal/Hr (15.4 Liters/Hr)
DIMENSIONS:.....H 87" (221 cm) x W 68" (172 cm) x L 123" (312 cm)
WEIGHT (Dry):.....2,570 lbs. (1,166 kg)

* For Flows and Pressures Other Than Standard, Consult Factory

Since we are constantly working to improve our products, specifications are subject to change without notice.



167 Stock Street, Nesquehoning, PA 18240 Phone: 570-645-3779 Fax: 570-645-4061

Website: www.hydra-tech.com

E-Mail: htpump@hydra-tech.com