

HYDRAULIC POWER UNIT

MODEL HT60EV

The HT60EV power unit is driven by a 60HP TEFC electric motor for use where electric power is available. It is designed to drive several of our pump models plus many other hydraulic tools and equipment.

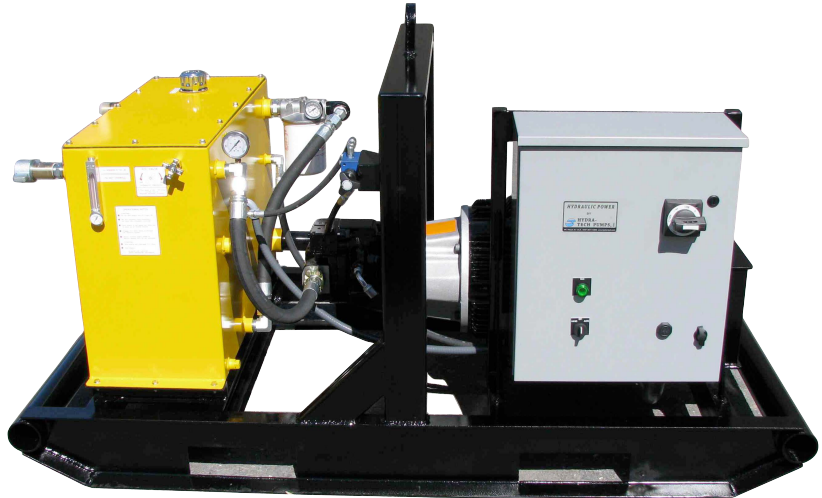

Unit Shown with Optional Control Panel

FEATURES

- Skid Frame Chassis with Fork Slots
- Single Point Lifting Bracket
- Variable Piston Hydraulic Pump
- Case Drain Oil Cooler
- Variable Output Control
- Spin-On Return Filter W/ Indicator
- Tank Top Filler/ Strainer
- System Relief Valve
- Pressure Control Valve
- Liquid Filled Pressure Gauge
- Fluid Level/ Temperature Gauge

OPTIONS

- Control Panels
- 575 Volts; 50Hz
- Highway Trailer
- Low Oil / High Temp Shutdown
- Directional Valves

A0516

Model HT60EV Overall Dimensions

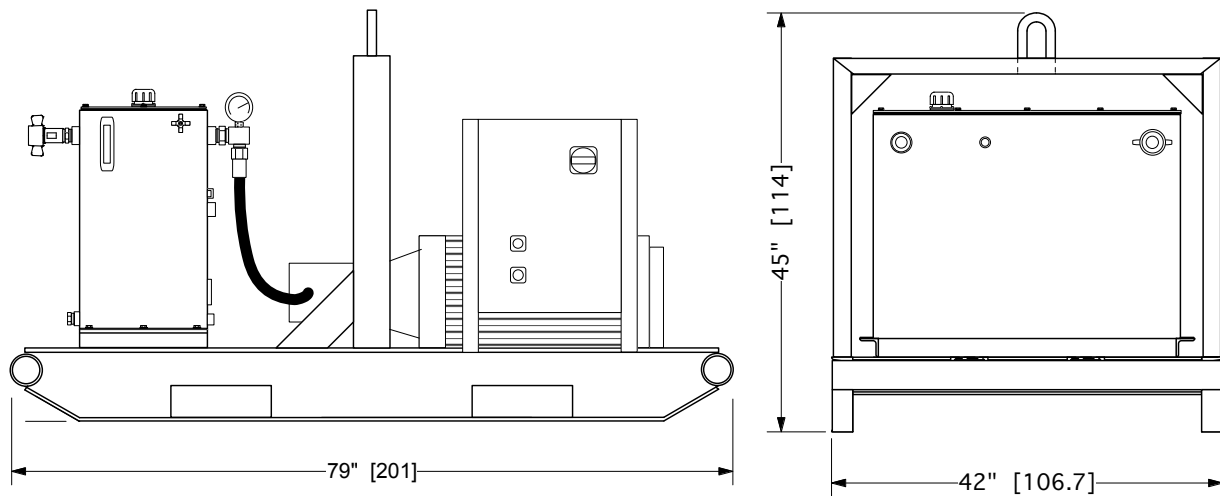

HT60EV SPECIFICATIONS

MOTOR:..... 60 HP 230/460 Volts, 3 Phase, 60 Hz, TEFC
SPEED:..... 1775 RPM
FULL LOAD AMPS:..... 154/77
HYDRAULIC OUTPUT*:..... Variable, Max. 30 GPM (114 LPM)
OPERATING PRESSURE*:..... Maximum 3200 PSI (218 Bar)
HOSE PORT SIZE:..... 1"
HYDRAULIC OIL:..... SAE 10W or 20W (ISO 32 or 46) Type AW
..... also: Biodegradable oil (Consult Factory)
OIL FILTRATION:..... 10 Micron (Standard)
OIL RESERVOIR CAPACITY:..... 50 U.S. Gallons (113 Liters)
DIMENSIONS:..... H 45" (114 cm) x W 42" (107 cm) x L 79" (200 cm)
WEIGHT (Dry):..... 1300 lbs. (770 kg)

* For Flows and Pressures Other Than Standard, Consult Factory

Since we are constantly working to improve our products, specifications are subject to change without notice.



167 Stock Street, Nesquehoning, PA 18240 Phone: 570-645-3779 Fax: 570-645-4061
Website: www.hydra-tech.com E-Mail: htpump@hydra-tech.com