

PORTABLE HYDRAULIC POWER

UNIT MODEL HT10E

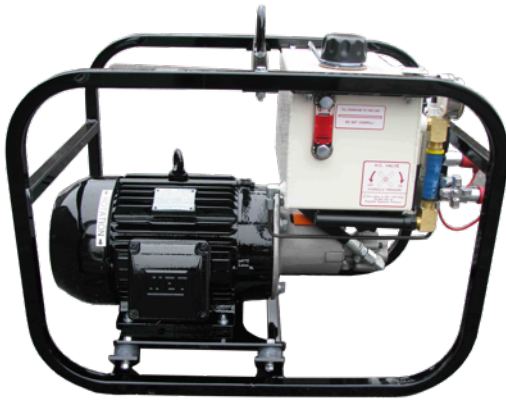

The HT10E power unit is driven by a 10HP electric motor for use where electric power is available. It is designed to drive several of our pump models including the S3T, S3TC and S6P. Other hydraulic tools and equipment may also operate from this power unit.

FEATURES

- Roll Cage Chassis
- Single Point Lifting Bracket
- Gear Type Hydraulic Pump
- TEFC Electric Motor
- Hydraulic Oil Cooler
- Spin-On Return Filter W/ Indicator
- Tank Top Filler/ Strainer
- System Relief Valve
- Hydraulic Control Valve
- Liquid Filled Pressure Gauge
- Fluid Level/ Temperature Gauge

OPTIONS

- Single Phase 220 Volts
- 575 Volts; 50Hz
- Control Panels
- Explosion Proof Motor

A0245

Model HT10E Overall Dimensions

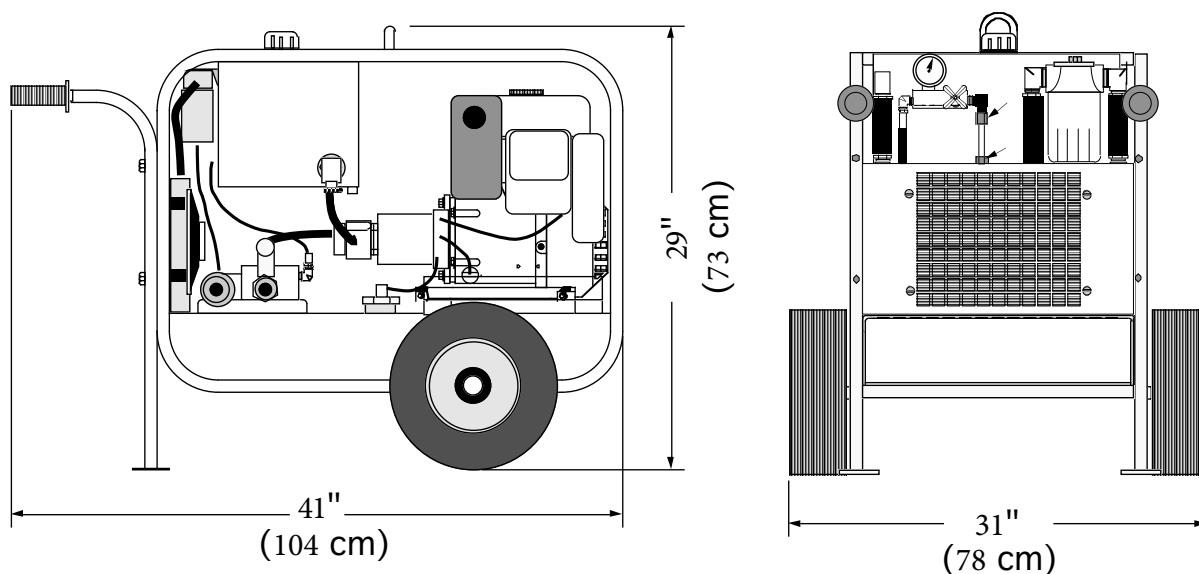

SPECIFICATIONS

MOTOR:..... 10 HP 230/460 Volts, 3 Phase, 60 Hz, TEFC
SPEED:..... 3600 RPM
FULL LOAD AMPS:..... 24/12
HYDRAULIC OUTPUT*:..... 6 GPM (23 LPM)
OPERATING PRESSURE*:..... Maximum 2500 PSI (170 Bar)
HOSE PORT SIZE:..... 1/2"
HYDRAULIC OIL:..... SAE 10W or 20W (ISO 32 or 46) Type AW
also: Dexron ATF or Biodegradable Oil
OIL FILTRATION:..... 10 Micron (Standard)
OIL RESERVOIR CAPACITY:..... 4 U.S. Gallons (15 Liters)
DIMENSIONS: (Roll Cage).....H 25" (64 cm) x W 20" (51 cm) x L 30" (76 cm)
(With Wheel Kit) H 29" (73 cm) x W 31" (78 cm) x L 41" (104 cm)
WEIGHT (Dry):..... 185 lbs.

* For Flows and Pressures Other Than Standard, Consult Factory

Since we are constantly working to improve our products, specifications are subject to change without notice.



167 Stock Street, Nesquehoning, PA 18240 Phone: 570-645-3779 Fax: 570-645-4061

Website: www.hydra-tech.com

E-Mail: htpump@hydra-tech.com