

PORTABLE HYDRAULIC POWER UNIT MODEL HT7DXR

This compact diesel power unit features an extended run fuel tank, extra oil cooling and easy handling. Great for continuous duty applications powering our pumps or other hydraulic equipment.



FEATURES

- Yanmar Tier IV Final air-cooled Diesel Engine
- Roll Cage Frame with Single Point Lifting Eye
- Gear-Type Hydraulic Pump
- Spin-On Return Filter W/ Indicator
- Variable Speed Throttle Controls Hydraulic Output
- Hydraulic Oil Cooler
- Tank Top Filler/ Strainer
- HTMA Quick - Disconnect Couplings
- System Relief Valve
- 15 Gallon Fuel Cell
- Liquid Filled Pressure Gauge
- Fluid Level/ Temperature Gauge
- Fuel Level Gauge
- Made in USA

OPTIONS

- Electric Start (HT7DXRE model)
- Other Flow and Pressure Combinations

A0516

Model HT7DXR Overall Dimensions

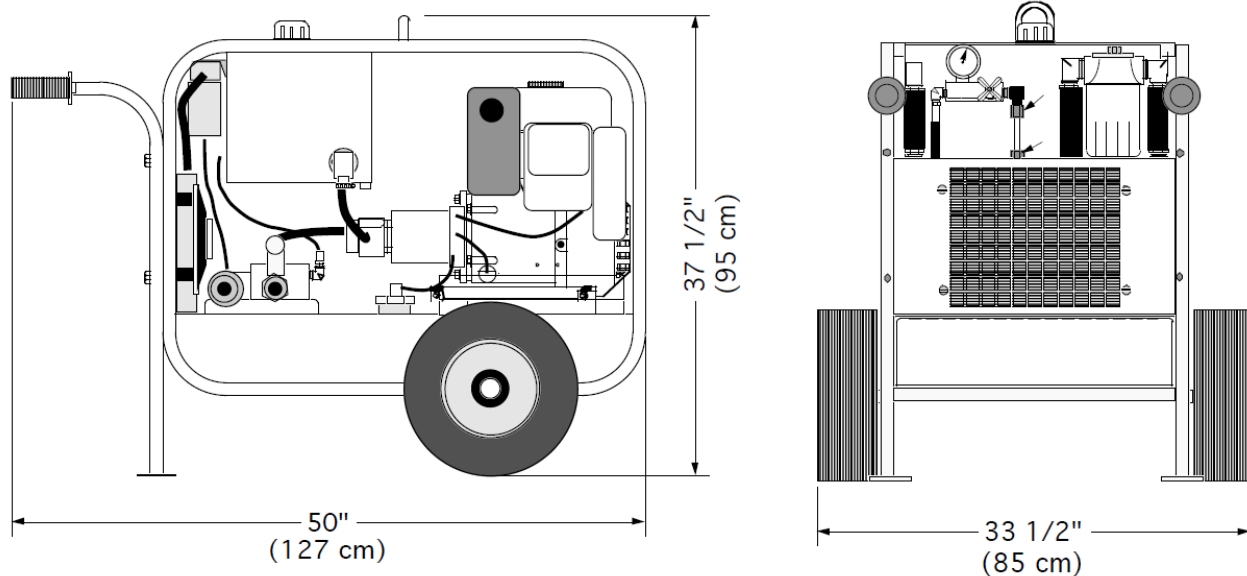

SPECIFICATIONS

ENGINE:..... Yanmar L70V Diesel (Tier IV Final)
HORSE POWER:..... 6 @ 3600 RPM
HYDRAULIC OUTPUT:..... Variable, Max 4.5 GPM (17 LPM)
OPERATING PRESSURE:..... Maximum 1800 PSI (122 Bar)
HOSE PORT SIZE:..... 1/2" NPT
HYDRAULIC OIL:..... SAE 10W or 20W Type AW
also: Dexron ATF or Biodegradable oil
OIL FILTRATION:..... 10 Micron (Standard)
OIL RESERVOIR CAPACITY:..... 8 U.S. Gallons (30 Liters)
FUEL TANK CAPACITY:..... 15 U.S. Gallons (57 Liters)
FUEL CONSUMPTION:..... Approx. .5 U.S. Gal/Hr (2 Liters/Hr)
DIMENSIONS:.... H 37 1/2" (95 cm) x W 33 1/2" (85 cm) x L 50" (127 cm)
WEIGHT (Dry):..... 380 lbs. (172 kg)

* For Flows and Pressures Other Than Standard, Consult Factory

Since we are constantly working to improve our products, specifications are subject to change without notice.



167 Stock Street, Nesquehoning, PA 18240 Phone: 570-645-3779 Fax: 570-645-4061

Website: www.hydra-tech.com

E-Mail: htpump@hydra-tech.com