

PORTABLE HYDRAULIC POWER UNIT

MODEL HT45DIV

This hydraulic power unit is powered by an Isuzu diesel engine and is designed to drive several of our pump models including the S6CSL, S6TC and S12M. Other hydraulic tools and equipment that require flows to 22 GPM can also operate from this power unit.



FEATURES

- Highway Trailer Chassis with Built-In Fuel Tank and Independent Suspension
- Single Point Lifting Bracket
- Engine Safety Shutdown Package
- Pressure Compensated Variable Volume Hydraulic Pump
- Hydraulic Oil Cooler
- Variable Speed Control
- Spin-On Return Filter W/ Indicator
- Tank Top Filler/ Strainer
- Made in USA
- System Relief Valve
- Pressure Control Valve
- Liquid Filled Pressure Gauge
- Fluid Level/ Temperature Gauge

OPTIONS

- Skid Frame
- Multiple Hydraulic Circuits
- Other Flow and Pressure Combinations
- Float Switch Operation

A0116

Model HT45DIV Overall Dimensions

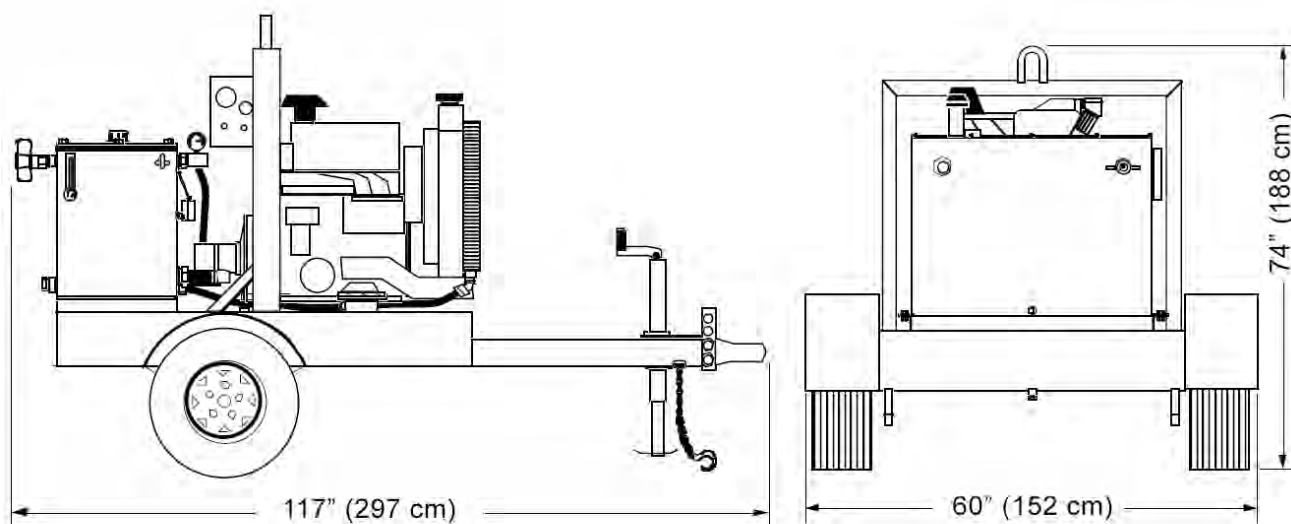

SPECIFICATIONS

ENGINE:.....Isuzu AZ-4LE2T liquid cooled Diesel (Tier 4 Final)
POWER:..... 48 HP(36 KW) @ 2400 RPM
HYDRAULIC OUTPUT*:..... Variable, Max. 22 GPM (83 LPM)
OPERATING PRESSURE*:..... Maximum 3000 PSI (204 Bar)
HOSE PORT SIZE:..... 3/4" NPT
HYDRAULIC OIL:..... SAE 10W or 20W (ISO 32 or 46) Type AW
..... also: Biodegradable oil (Consult Factory)
OIL FILTRATION:..... 10 Micron (Standard)
OIL RESERVOIR CAPACITY:..... 30 U.S. Gallons (113 Liters)
FUEL TANK CAPACITY:..... 46 U.S. Gallons (157 Liters)
FUEL CONSUMPTION:..... Approx. 2 U.S. Gal/Hr (7.6 Liters/Hr)
DIMENSIONS:..... H 74" (188 cm) x W 60" (152 cm) x L 117" (297 cm)
WEIGHT (Dry):..... 2161 lbs. (937 kg)

* For Flows and Pressures Other Than Standard, Consult Factory

Since we are constantly working to improve our products, specifications are subject to change without notice.



167 Stock Street, Nesquehoning, PA 18240 Phone: 570-645-3779 Fax: 570-645-4061

Website: www.hydra-tech.com

E-Mail: htpump@hydra-tech.com