

## PORTABLE HYDRAULIC POWER UNIT

### MODEL HT35DD

This power unit is driven by a Deutz air cooled diesel engine and is designed to drive several of our pump models including the S4VHL. A large, built-in fuel tank allows this unit to run up to 24 hours between refills. Other equipment that require flows to 20 GPM may also operate from this power unit.

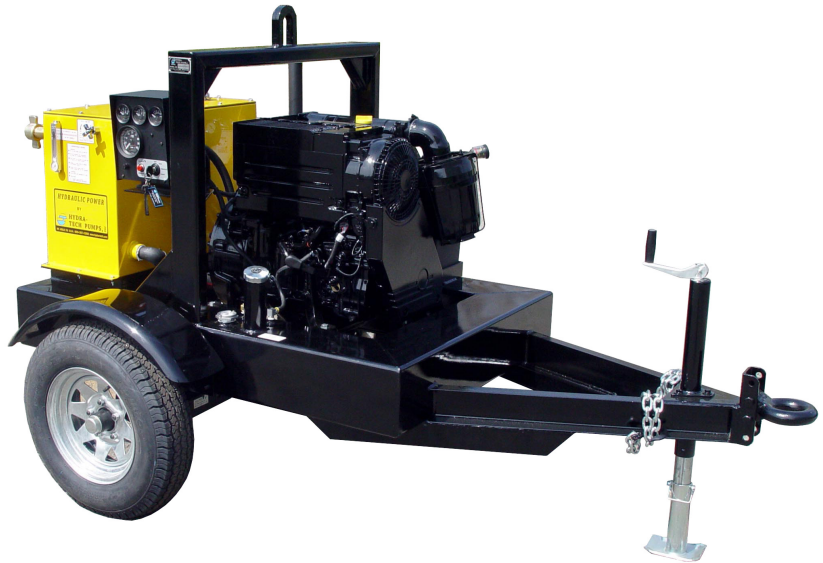

## FEATURES

- Highway Trailer Chassis with Built-In Fuel Tank and Independent Suspension
- Single Point Lifting Bracket
- Automatic Engine Safety Shutdown Package
- Vane-Type Hydraulic Pump
- Spin-On Return Filter W/ Indicator
- Variable Speed Control
- Tank Top Filler/ Strainer
- System Relief Valve
- Pressure Control Valve
- Liquid Filled Pressure Gauge
- Fluid Level/ Temperature Gauge

### OPTIONS

- Skid Frame
- Multiple Hydraulic Circuits
- Other Flow and Pressure Combinations

A0116

## Model HT35DD Overall Dimensions

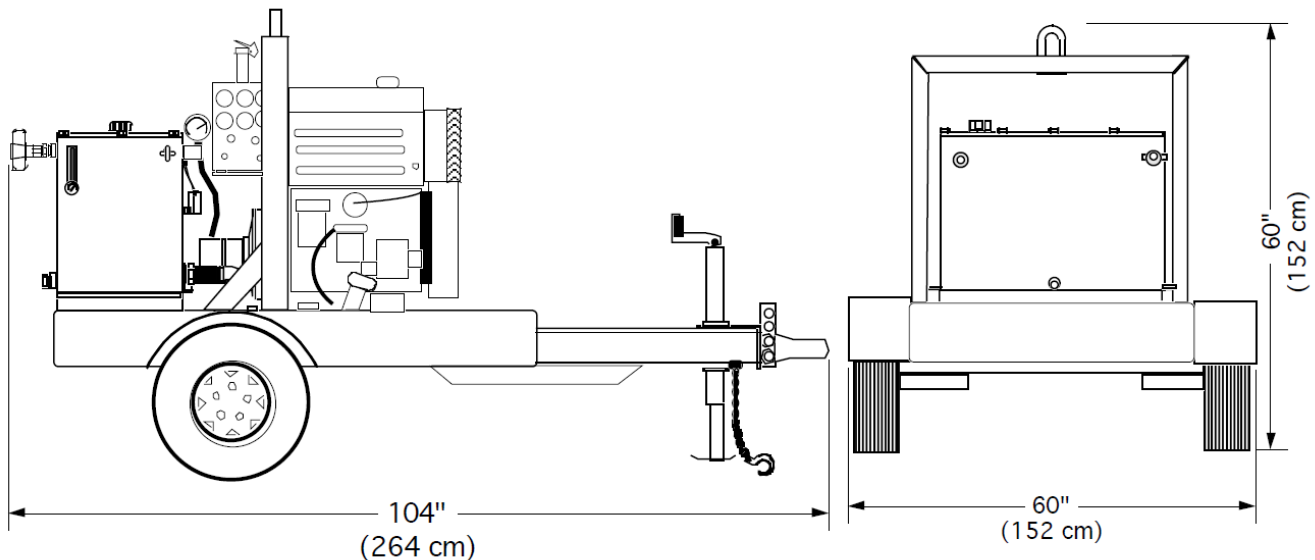

## SPECIFICATIONS

ENGINE:..... Deutz D2011L03 Air Cooled Diesel (Tier 3)  
HORSEPOWER:..... 35 @ 2300 RPM  
HYDRAULIC OUTPUT\*:..... Variable, Max. 20 GPM (76 LPM)  
OPERATING PRESSURE\*:..... Maximum 2500 PSI (170 Bar)  
HOSE PORT SIZE:..... 3/4" or 1" NPT  
HYDRAULIC OIL:..... SAE 10W or 20W Type AW  
..... also: Biodegradable oil (Consult Factory)  
OIL FILTRATION:..... 10 Micron (Standard)  
OIL RESERVOIR CAPACITY:..... 30 U.S. Gallons (114 Liters)  
FUEL TANK CAPACITY:..... 40 U.S. Gallons (151 Liters)  
FUEL CONSUMPTION:..... Approx. 1.7 U.S. Gal/Hr (6.4 Liters/Hr)  
DIMENSIONS:..... H 60" (152 cm) x W 60" (152 cm) x L 104" (264 cm)  
WEIGHT (Dry):..... 1580 lbs. (716 kg)

\* For Flows and Pressures Other Than Standard, Consult Factory

Since we are constantly working to improve our products, specifications are subject to change without notice.



167 Stock Street, Nesquehoning, PA 18240 Phone: 570-645-3779 Fax: 570-645-4061

Website: [www.hydra-tech.com](http://www.hydra-tech.com)

E-Mail: [htpump@hydra-tech.com](mailto:htpump@hydra-tech.com)