

PORTABLE HYDRAULIC POWER UNIT

MODEL HT20DQP

This small sound attenuated diesel unit is designed to be used in areas where lower sound levels are required. Hydraulic flow can be dialed in to match the tool being used. Perfect for driving hydraulic tools and our submersible pumps.



FEATURES

- Lightweight Aluminum Chassis with Single Point Lifting Bracket
- Enclosure with Sound Proofing, Hinged Doors and Folding Handles
- Fixed Displacement Hydraulic Pump
- Engine Safety Shutdown Panel
- Variable Flow Control Valve
- Efficient Hydraulic Oil Cooler
- Hydraulic Flow Meter
- Variable Speed Control
- System Relief Valve
- Pressure Control Switch
- Liquid Filled Pressure Gauge
- Fluid Level/ Temperature Gauge
- Recessed Hose Connections

OPTIONS

- Fork Tubes
- Other Flow and Pressure Combinations

A0116

Model HT20DQP Overall Dimensions

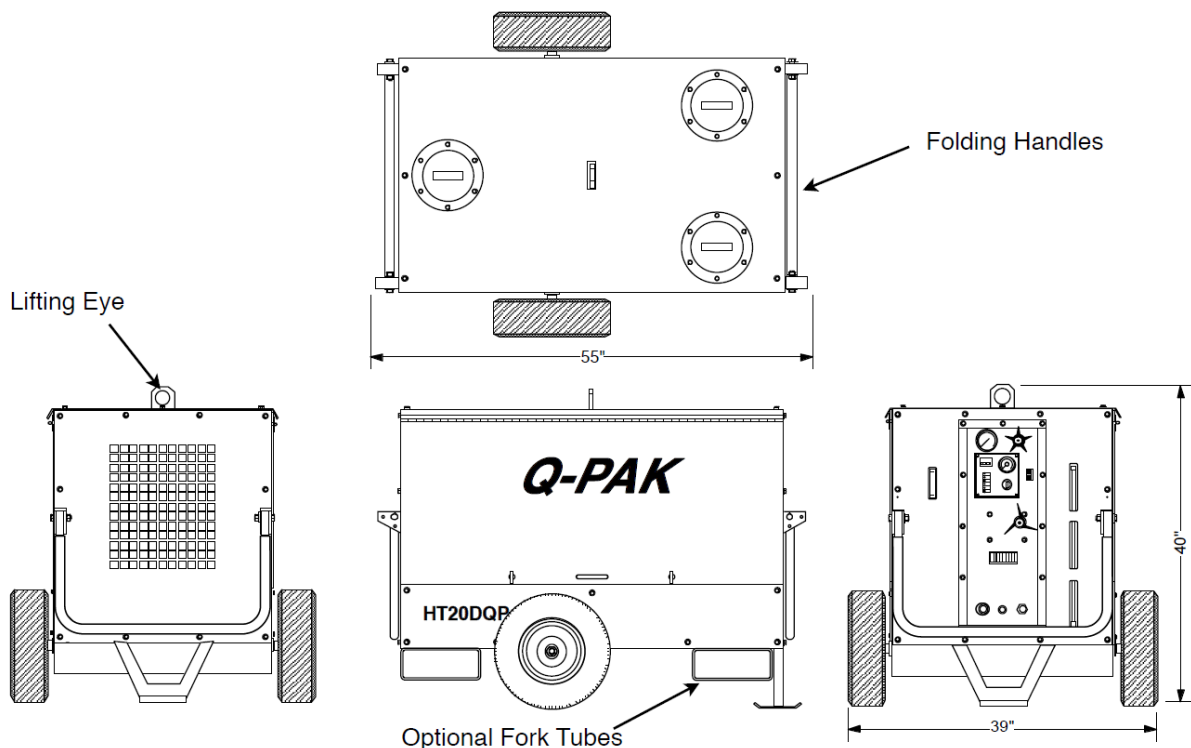

SPECIFICATIONS

ENGINE:	Yanmar 3TNM72 Diesel (Tier 4)
HORSEPOWER:	23 @ 3000 RPM
HYDRAULIC OUTPUT*:	Variable, Max. 11 GPM (42 LPM)
OPERATING PRESSURE*:	Maximum 2500 PSI (170 Bar)
HOSE PORT SIZE:	(Pressure and Return)... 1/2" (Case Drain)... 3/8"
HYDRAULIC OIL:	(Standard) SAE 20W (ISO 46) Type AW also: Biodegradable Oil (Consult Factory)
OIL FILTRATION:	10 Micron (Standard)
OIL RESERVOIR CAPACITY:	9 U.S. Gallons (34 Liters)
FUEL TANK CAPACITY:	9 U.S. Gallons (34 Liters)
FUEL CONSUMPTION:	Approx. 1.2 U.S. Gal/Hr (4.5 Liters/Hr)
NOISE LEVELS (Approx.):	88 dB @ 10 Ft. (3M), 82 dB @ 23 Ft. (7M)
DIMENSIONS:	OAL: 55" (140 cm) with handles stowed 81" (206 cm) with handles extended ..OAW: 39" (99 cm), OAH: 40" (102 cm)
WEIGHT (Dry):	650 lbs. (295 kg)

* For Flows and Pressures Other Than Standard, Consult Factory

Since we are constantly working to improve our products, specifications are subject to change without notice.



167 Stock Street, Nesquehoning, PA 18240 Phone: 570-645-3779 Fax: 570-645-4061

Website: www.hydra-tech.com

E-Mail: htpump@hydra-tech.com