

PORTABLE HYDRAULIC POWER UNIT

MODEL HT11D

This portable and rugged diesel power pack is ideal for driving our 3" trash pumps and even our 6" high-volume propeller pump. It also can provide hydraulic power to run many other hydraulic tools using the variable speed throttle to control hydraulic output.



Unit shown with optional wheel kit

FEATURES

- Yanmar air-cooled Diesel Engine with Electric Start
- Roll Cage Frame with Single Point Lifting Eye
- Gear-Type Hydraulic Pump
- Spin-On Return Filter W/ Indicator
- Variable Speed Throttle Controls Hydraulic Outputs
- Hydraulic Oil Cooler
- Tank Top Filler/ Strainer
- HTMA Quick - Disconnect Couplings
- System Relief Valve
- Made in USA
- Liquid Filled Pressure Gauge
- Fluid Level/ Temperature Gauge

OPTIONS

- Wheel Kit
- Other Flow and Pressure Combinations

A0116

Model HT11D Overall Dimensions

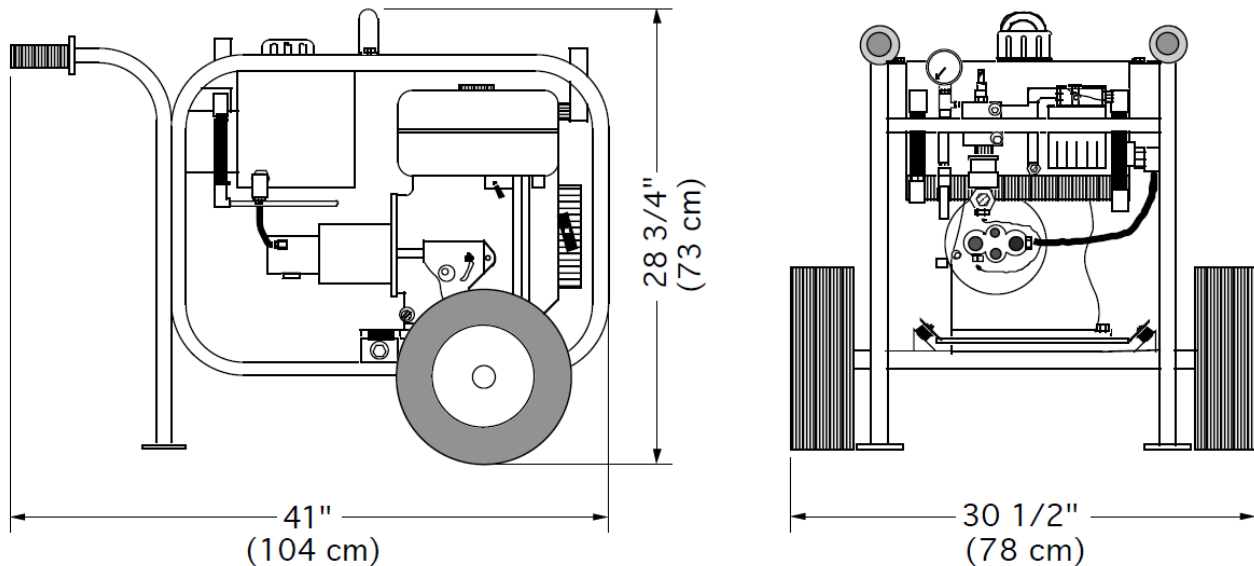

SPECIFICATIONS

ENGINE:.....Yanmar L100W Diesel
HORSE POWER:..... 9.1 @ 3500 RPM
HYDRAULIC OUTPUT:..... Variable Max 6 GPM (23 LPM)
OPERATING PRESSURE:..... Maximum 2000 PSI (138 Bar)
HOSE PORT SIZE:..... 1/2" NPT
HYDRAULIC OIL:..... SAE 10W or 20W Type AW
also...Dexron ATF or Biodegradable Oil
OIL FILTRATION:..... 10 Micron (Standard)
OIL RESERVOIR CAPACITY:..... 4 U.S. Gallons (15.1 Liters)
FUEL TANK CAPACITY:..... 1.2 U.S. Gallons (4.7 Liters)
FUEL CONSUMPTION:..... Approx. .5 U.S. Gal/Hr (1.9 Liters/Hr)
DIMENSIONS:..... H 25" (63.5 cm) x W 20" (51 cm) x L 30" (76 cm)
w/ Wheel Kit: H 28 3/4" (73 cm) x W 30 1/2" (78 cm) x L 41" (104 cm)
WEIGHT (Dry):..... 225lbs. (102 kg)

* For Flows and Pressures Other Than Standard, Consult Factory

Since we are constantly working to improve our products, specifications are subject to change without notice.



167 Stock Street, Nesquehoning, PA 18240 Phone: 570-645-3779 Fax: 570-645-4061

Website: www.hydra-tech.com

E-Mail: htpump@hydra-tech.com