

## PORTABLE HYDRAULIC POWER UNIT

### MODEL HT100DJV



Our high performance 100 H.P. model features a John Deere turbocharged 4 cylinder diesel and pressure compensated hydraulic pump. It is designed to drive our larger submersible pumps or other hydraulic equipment requiring flows to 53 GPM and pressures to 2500 PSI.

## FEATURES

- Skid Frame Chassis with built-in Extended-Run Fuel Tank and Fork-Lift Slots
  - Single Point Lifting Bracket and Tie Downs for Transport
  - Automatic Engine Safety Shutdown
  - Variable Volume Piston Hydraulic Pump
  - Efficient Hydraulic Oil Cooler
  - Dual Spin-On Return Filter w/Indicator
  - Variable Speed Control
  - Tank Top Filler/ Strainer
  - System Relief Valve
  - Made in USA
  - Liquid Filled Pressure Gauge
  - Fluid Level/ Temperature Gauge
- OPTIONS**
- Highway Trailer with Independent Suspension
  - D.O.T. Brakes and Lights
  - Multiple Hydraulic Circuits
  - Other Flow and Pressure Combinations
  - Float Switch Control Operation

A0116

## Model HT100DJV Overall Dimensions

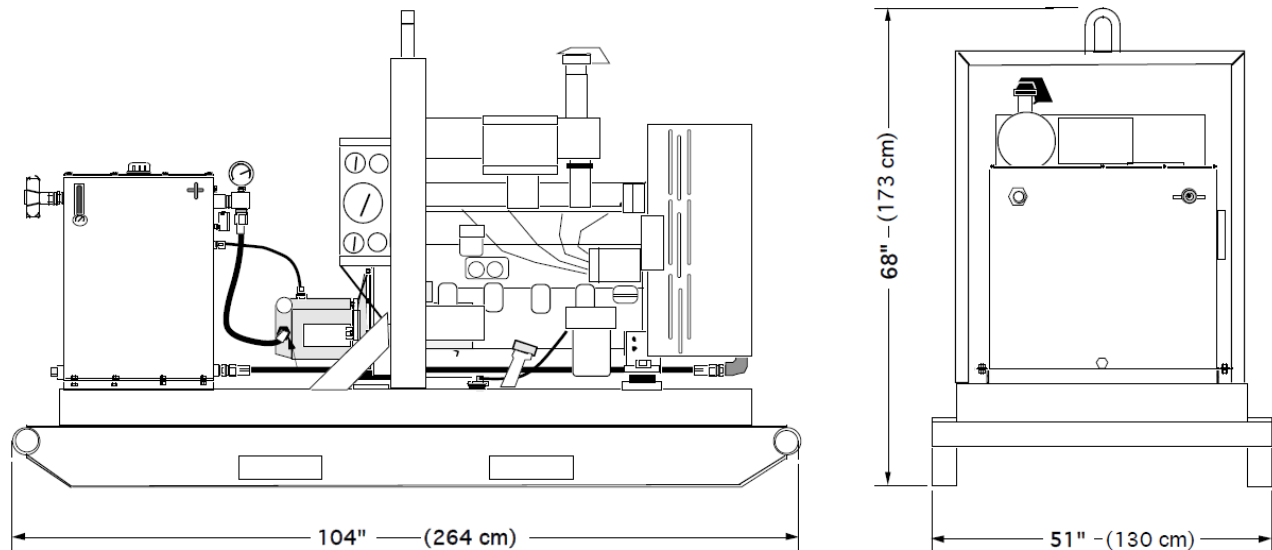

## SPECIFICATIONS

ENGINE:..... John Deere Diesel (Tier IV Final)  
HORSE POWER:..... 99 @ 2400 RPM  
HYDRAULIC OUTPUT\*:..... Variable Max 53 GPM (201 LPM)  
OPERATING PRESSURE\*:..... Maximum 2500 PSI (170 Bar)  
HOSE PORT SIZE:..... 1 1/4" NPT  
HYDRAULIC OIL:..... SAE 10W or 20W Type AW  
also: Biodegradable oil (Consult Factory)  
OIL FILTRATION:.....10 Micron (Standard)  
OIL RESERVOIR CAPACITY:..... 75 U.S. Gallons (284 Liters)  
FUEL TANK CAPACITY:..... 88 U.S. Gallons (333 Liters)  
FUEL CONSUMPTION:..... Approx. 6 U.S. Gal/Hr (23 Liters/Hr)  
DIMENSIONS:..... H 68" (173 cm) x W 51" (130 cm) x L 104" (264 cm)  
WEIGHT (Dry):..... 2800 lbs. (1268 kg)

\* For Flows and Pressures Other Than Standard, Consult Factory

Since we are constantly working to improve our products, specifications are subject to change without notice.



167 Stock Street, Nesquehoning, PA 18240 Phone: 570-645-3779 Fax: 570-645-4061

Website: [www.hydra-tech.com](http://www.hydra-tech.com)

E-Mail: [htpump@hydra-tech.com](mailto:htpump@hydra-tech.com)