

6" HYDRAULIC SUBMERSIBLE SEWAGE/WASTEWATER PUMP

MODELS

S6V (Ductile Iron Body)

S6VAL (Aluminum Body)

6" (15 cm) Discharge

The S6V, a 6" discharge sewage pump, designed specifically to easily pass through a 21" manhole which makes it ideal for sewer by-pass jobs. This pump is durable, compact and able to pass large solids, stringy material and slurries with entrained gases. Flows to 1550 gpm.



FEATURES

- Semi Recessed SS Vortex Impeller (will pass 5" semi-solids)
- Compact Design allows this pump to fit through a 21" opening
- Variable Speed hydraulic drive provides a wide range of performance
- Oil Lubricated Seals (can run dry)
- Dependable gear type hydraulic motor
- Can be bolted directly into a pipeline or used as a booster pump
- Safe Hydraulic Drive can be used where electric power is hazardous or impractical
- Operates with our HT50 to HT75 power units or other hydraulic power sources capable of flows of 15 - 30 GPM
- Stainless Steel model available

D0516

SPECIFICATIONS

WEIGHT: S6V (ductile iron).....	247 lbs. (112 kg)
S6VAL(aluminum).....	164 lbs. (74 kg)
HEIGHT:.....	34" (86 cm)
DIAMETER (@ widest point):.....	20-3/4" (53 cm)
DISCHARGE:.....	6" NPT(F)
INLET FLANGE:.....	6" 125# ANSI
SOLIDS HANDLING:.....	W/O Strainer..5" (12.7 cm)
	With Strainer..2-1/2" (6.3 cm)
HOSE PORTS:.....	1" (-16) SAE
PUMP BODY: S6V.....	Ductile Iron
S6VAL.....	Aluminum
IMPELLER:.....	Stainless Steel
WEAR RING.....	ASTM A36 Steel
SHAFT:.....	17-4 PH Stainless Steel
SHAFT SEAL:.....	Carbon / Ceramic (Std)
	Silicon Carbide (Opt)
ELASTOMERS:.....	Buna N (Std)
HYDRAULIC OIL:.....	214-320 s.s.u. @ 100°F (64°C)
INPUT FLOW:.....	Max. 30 GPM (114 LPM)
OPERATING PRESSURE:.....	Max 3000 PSI (204 Bar)
POWER SOURCE:.....	Any Open Center Hydraulic System

Specifications are subject to change without notice

Model S6V Overall Dimensions

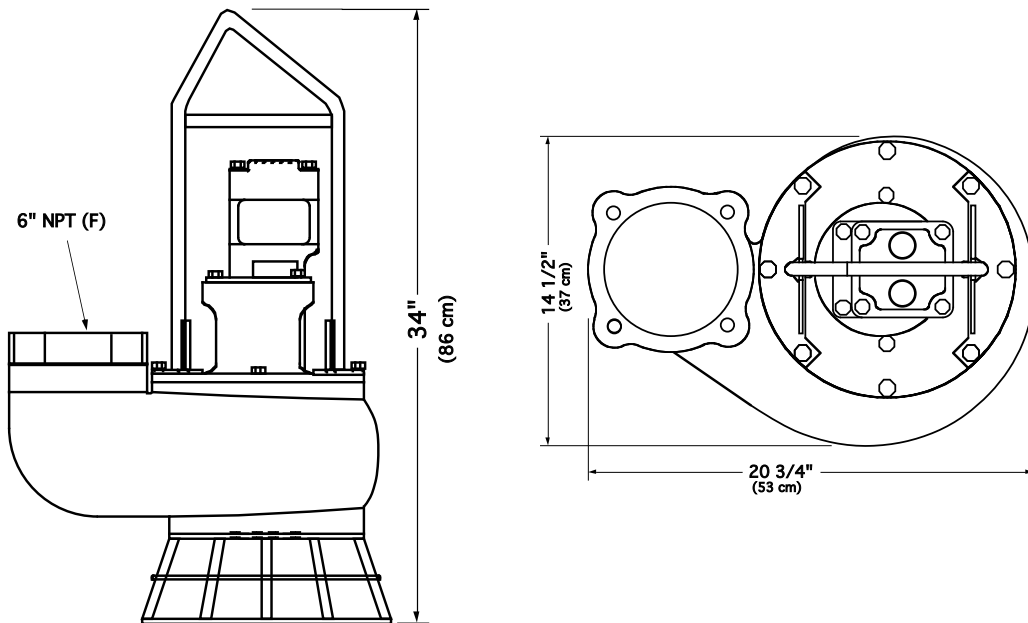

S6V Typical Performance

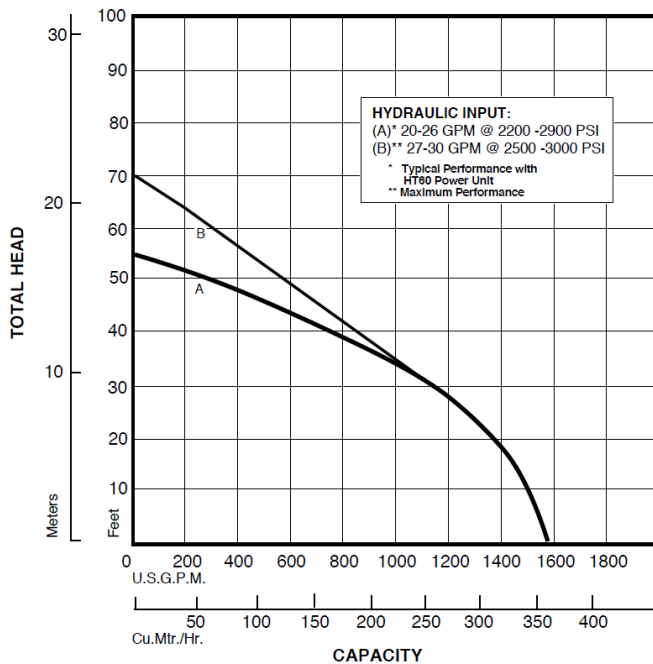

Curves are based on pumping water at 60°F. For performance curves other than shown above, consult factory.



167 Stock Street, Nesquehoning, PA 18240 Phone: 570-645-3779 Fax: 570-645-4061
 Website: www.hydra-tech.com E-Mail: htpump@hydra-tech.com