

4" HYDRAULIC SUBMERSIBLE UTILITY PUMP

MODELS S4SHR-LP

4" (10 cm) Discharge

The S4SHR-LP is a narrow version of the S4SHR. At only 21.5 inches wide it will fit through most manholes. This pump is designed to continuously rip and shear solids with a 360° shredding action. Great for municipal, industrial, agricultural and institutional waste applications.



FEATURES

- Open-Vane Shredder Impeller with Tungsten Carbide Cutting Tip
- Hardened Macerator Suction Plate
- Oil Lubricated Seals (can run dry)
- Variable Speed hydraulic drive to 2000 rpm
- Will Fit Into 22" Manholes
- Safe Hydraulic Drive can be used where electric power is hazardous or impractical
- Dependable gear type hydraulic motor
- Operates with our HT16 to HT35 power units or other hydraulic power sources capable of flows of 10 - 15 GPM

SPECIFICATIONS

WEIGHT:	225 lbs. (102 kg)
HEIGHT:	28" (71 cm)
WIDTH (w/Discharge elbow):	21 1/2" (55 cm)
(Across Volute):	16 3/4" (43 cm)
DISCHARGE:	4" NPT(F)
SOLIDS HANDLING:	3 1/2" (9 cm)
HOSE PORTS:	3/4" (-12) SAE(F)
PUMP BODY:	Ductile Iron
IMPELLER:	Ductile Iron
SHREDDER BLADE:	Tungsten Carbide
SHAFT:	Stainless Steel
SHAFT SEAL:	(Upper) Carbon/Ceramic (Lower) Silicon Carbide
ELASTOMERS:	Buna N
HYDRAULIC OIL:	214-320 s.s.u. @ 100°F (64°C)
INPUT FLOW:	Max. 15 GPM (57 LPM)
OPERATING PRESSURE:	Max. 3000 PSI (204 Bar)
POWER SOURCE:	Any Open Center Hydraulic System

D0516

Specifications are subject to change without notice

Model S4SHR-LP Overall Dimensions

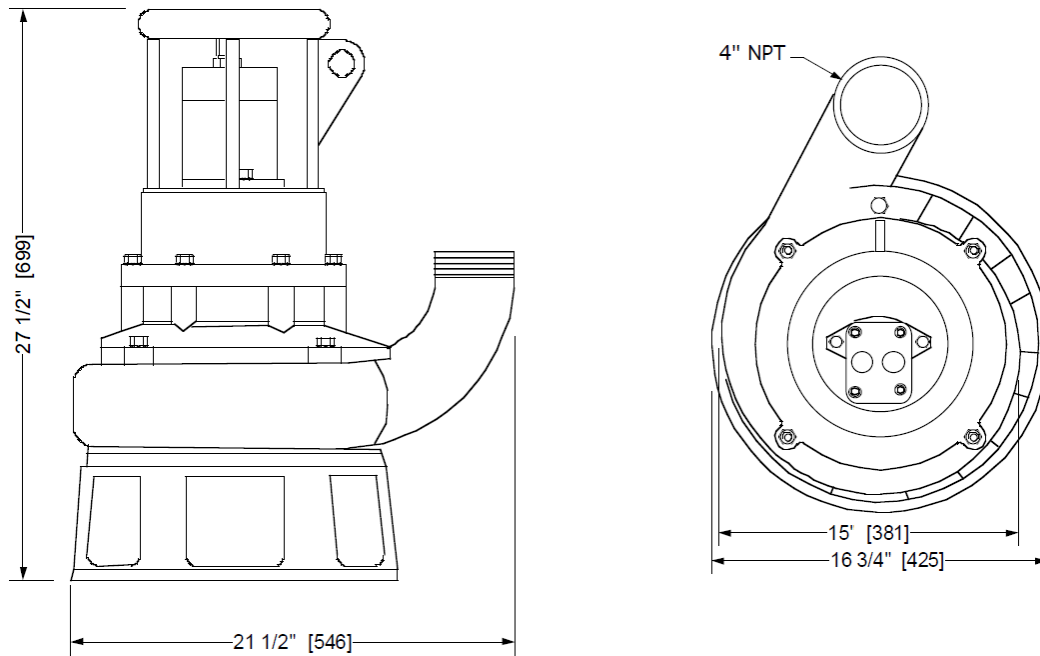

S4SHR-LP Typical Performance

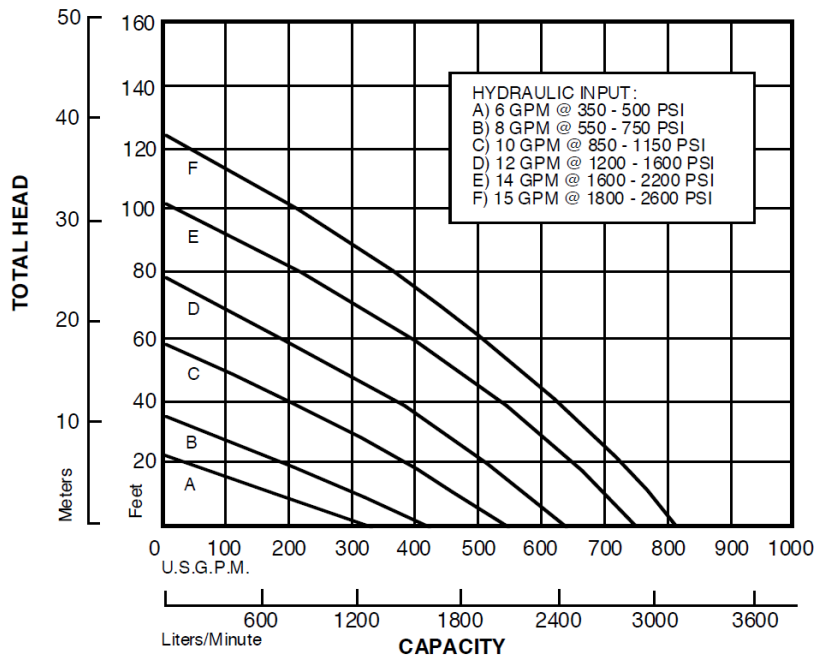

Curves are based on pumping water at 60°F. For performance curves other than shown above, consult factory.



167 Stock Street, Nesquehoning, PA 18240 Phone: 570-645-3779 Fax: 570-645-4061
Website: www.hydra-tech.com E-Mail: htpump@hydra-tech.com