



HYDRA-TECH PUMPS

3" HYDRAULIC SUBMERSIBLE VORTEX FLOW TRASH PUMP

MODEL S3T (Aluminum Body)

MODEL S3TDI (Ductile Iron Body)

3" (75 mm) Discharge

Our S3T model is designed for jobs such as construction sites and manhole pumping where lightweight, high volume, trash pumps are needed. It has the ability to pass through a 12" opening and pump in debris laden areas. A small hole strainer is available for limiting solids to be pumped.



FEATURES

- Stainless Steel Vortex Flow Impeller
- Oil Lubricated Seals (can run dry)
- Variable Speed hydraulic drive
- Small overall size for use tight spaces
- Can be bolted directly into a pipeline
- Safe Hydraulic Drive can be used where electric power is hazardous or impractical
- Dependable gear type hydraulic motor
- Operates with our HT11 to HT15 power units or other hydraulic power sources capable of flows of 5-8 GPM

SPECIFICATIONS

WEIGHT	S3T:.....	25 lbs. (11 kg)
	S3TDI:.....	48 lbs. (22 kg)
HEIGHT:.....		14" (36 cm)
WIDTH (@ widest point):.....		11 3/4" (30 cm)
DISCHARGE:.....		3" NPT(F)
INLET FLANGE:.....		3", 125# ASA
SOLIDS HANDLING:.....		2 1/2" (63 mm)
HOSE PORTS:.....		1/2" NPT (F)
PUMP BODY	S3T:.....	Aluminum
	S3TDI:.....	Ductile Iron
IMPELLER:.....		Stainless Steel
WEAR RING:.....		Ductile Iron
SHAFT:.....		Plated 4140 Steel
SHAFT SEAL:.....		Carbon/Ceramic (Std)
ELASTOMERS:.....		Buna N (Std)
HYDRAULIC OIL:.....		214-320 s.s.u. @ 100°F (64°C)
INPUT FLOW:.....		Max. 8 GPM (30 LPM)
OPERATING PRESSURE:.....		Max. 2500 PSI (170 Bar)
POWER SOURCE:.....		Any Open Center Hydraulic System

C0109

Specifications are subject to change without notice



HYDRA-TECH PUMPS

167 Stock Street, Nesquehoning, PA 18240 Phone: 570-645-3779 Fax: 570-645-4061
Website: www.hydra-tech.com E-Mail: htpump@hydra-tech.com

Model S3T Overall Dimensions

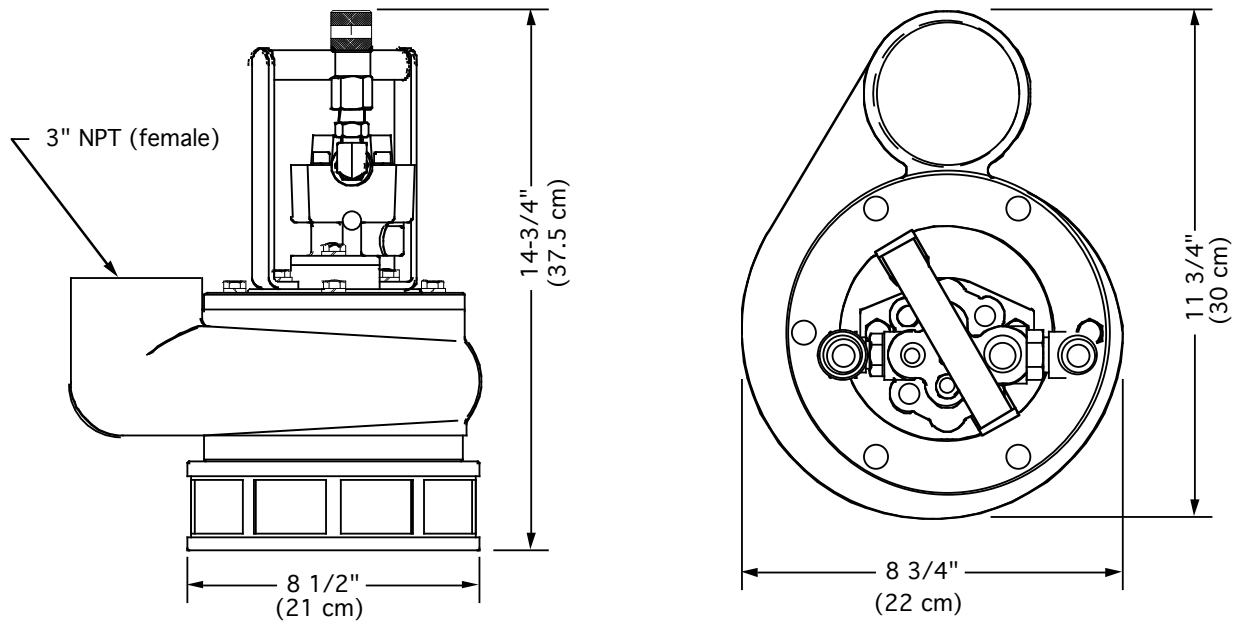

S3T Typical Performance

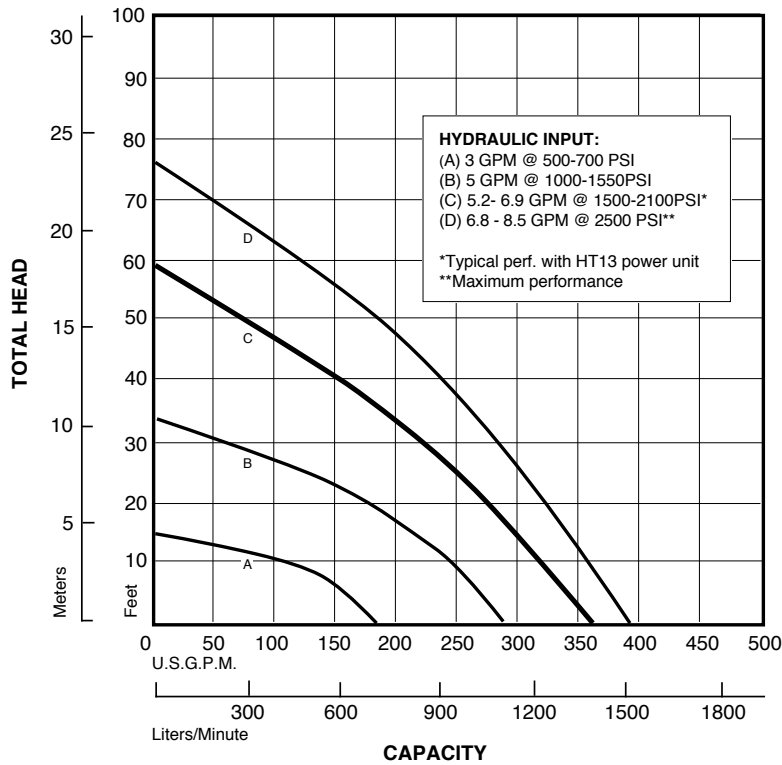

Curves are based on pumping water at 60°F. For performance curves other than shown above, consult factory.



167 Stock Street, Nesquehoning, PA 18240 Phone: 570-645-3779 Fax: 570-645-4061
 Website: www.hydra-tech.com E-Mail: htpump@hydra-tech.com