

3" HYDRAULIC SUBMERSIBLE SEWAGE/WASTEWATER PUMP

MODELS

S3TR (Aluminum Body)

S3TRDI (Ductile Iron Body)

3" (7.6 cm) Discharge

The S3TR model is designed for difficult pumping jobs where stringy solids are present. A fully recessed vortex impeller allows this pump to handle difficult solids found in sewage applications. It has the ability to pass through a 12 inch opening and continue to pump in debris laden job sites.



FEATURES

- Stainless Steel Vortex Flow Impeller
- Oil Lubricated Seals (can run dry)
- Variable Speed hydraulic drive
- Small overall size for use in tight spaces
- Can be bolted directly into a pipeline
- Safe Hydraulic Drive can be used where electric power is hazardous or impractical
- Dependable gear type hydraulic motor
- Operates with our HT11 to HT13 power units or other hydraulic power sources capable of flows of 5-8 GPM
- Stainless Steel model available

SPECIFICATIONS

WEIGHT	S3TR:.....	28 lbs. (13 kg)
	S3TRDI:.....	56 lbs. (25 kg)
HEIGHT:.....		15" (38 cm)
WIDTH (@ widest point):.....		11 3/4" (30 cm)
DISCHARGE:.....		3" NPT(F)
INLET FLANGE:.....		3" 125# ASA
SOLIDS HANDLING:.....		2 1/2" (6.3 cm)
HOSE PORTS:.....		1/2" NPT (F)
PUMP BODY	S3TR:.....	Aluminum
	S3TRDI:.....	Ductile Iron
IMPELLER:.....		Stainless Steel
WEAR RING:.....		Ductile Iron
SHAFT:.....		Plated 4140 Steel
SHAFT SEAL:.....		Carbon/Ceramic (Std)
ELASTOMERS:.....		Buna N (Std)
HYDRAULIC OIL:.....		214-320 s.s.u. @ 100°F (64°C)
INPUT FLOW:.....		Max. 8 GPM (30 LPM)
OPERATING PRESSURE:.....		Max. 2500 PSI (170 Bar)
POWER SOURCE:.....		Any Open Center Hydraulic System

D0516

Specifications are subject to change without notice

Model S3TR Overall Dimensions

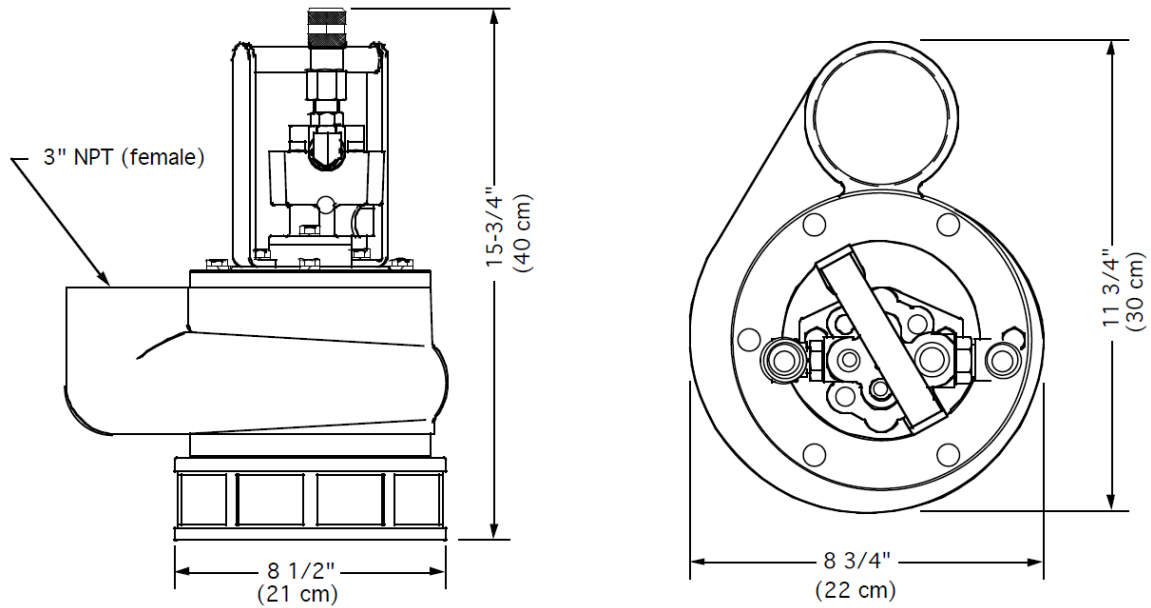

S3TR Typical Performance

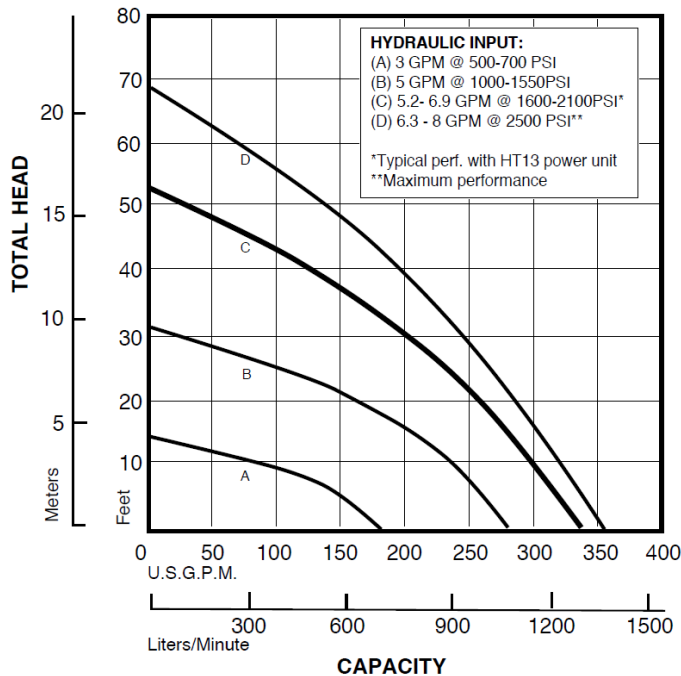

Curves are based on pumping water at 60°F. For performance curves other than shown above, consult factory.

