

3" HYDRAULIC SUBMERSIBLE SHREDDER PUMP

MODEL S3SHR

3" (8 cm) Discharge

The S3SHR is designed to continuously rip and shear solids with a 360° shredding action. The smaller size allows for use in tight spaces. For municipal, industrial, agricultural and institutional waste applications. A guide rail assembly is available for stationary applications.



FEATURES

- Dual-Vane Shredder Impeller with Tungsten Carbide Cutting Tip
- Hardened Macerator Suction Plate
- Oil Lubricated Seals (can run dry)
- Variable Speed hydraulic drive to 3800 rpm
- Versions for Portable or Fixed Installations
- Safe Hydraulic Drive can be used where electric power is hazardous or impractical
- Dependable gear type hydraulic motor
- Operates with our HT10 to HT20 power units or other hydraulic power sources capable of flows of 6 - 10 GPM

SPECIFICATIONS

WEIGHT:.....	73 Lbs. (33 kg)
HEIGHT:.....	18.5" (47 cm)
WIDTH (w/Discharge elbow):.....	15 1/4" (39 cm)
(Across Volute).....	9 1/2" (24 cm)
DISCHARGE:.....	3" NPT(F)
SOLIDS HANDLING:.....	1.6" (4 cm)
HOSE PORTS:.....	5/8 (-10) SAE(F)
PUMP BODY:.....	Ductile Iron
IMPELLER:.....	Ductile Iron
SHREDDER BLADE:.....	Tungsten Carbide
SHAFT:.....	Stainless Steel
SHAFT SEAL:.....	(Upper) Carbon/Ceramic (Lower) Silicon Carbide
ELASTOMERS:.....	Buna N
HYDRAULIC OIL:.....	214-320 s.s.u. @ 100°F (64°C)
INPUT FLOW:.....	Max. 10 GPM (38 LPM)
OPERATING PRESSURE:.....	Max. 3000 PSI (204 Bar)
POWER SOURCE:.....	Any Open Center Hydraulic System

D0516

Specifications are subject to change without notice

Model S3SHR Overall Dimensions

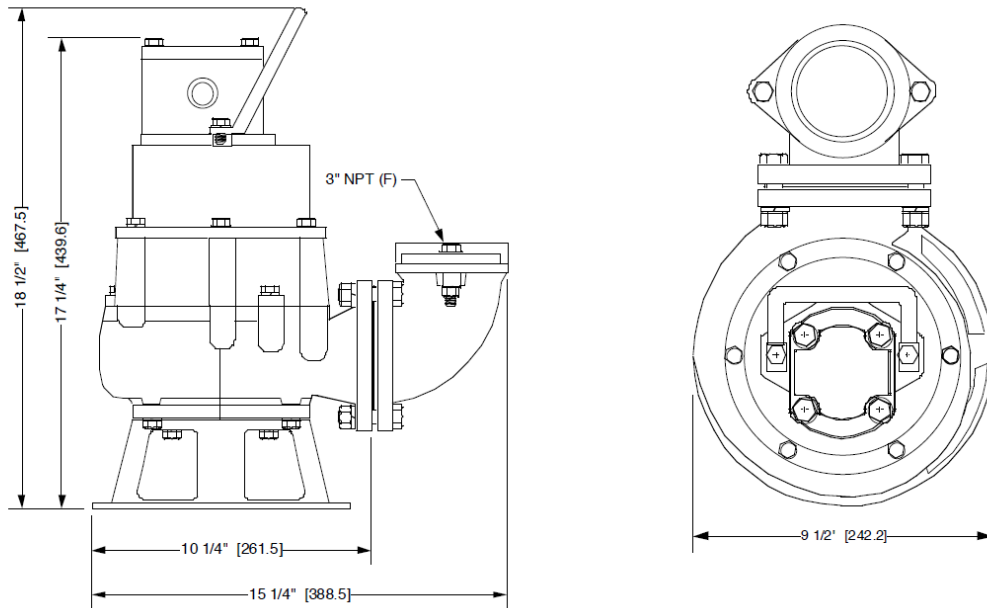

S3SHR Typical Performance

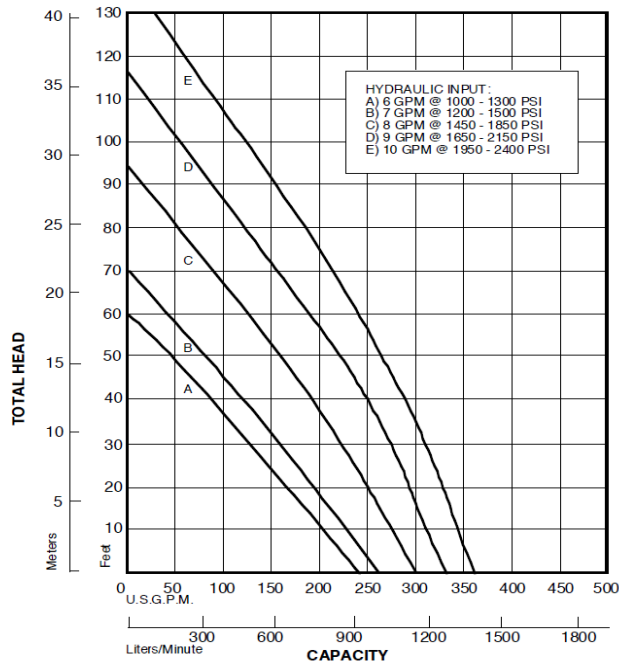

Curves are based on pumping water at 60°F. For performance curves other than shown above, consult factory.



167 Stock Street, Nesquehoning, PA 18240 Phone: 570-645-3779 Fax: 570-645-4061
 Website: www.hydra-tech.com E-Mail: htpump@hydra-tech.com