

TYPICAL HYDRAULIC SCHEMATIC FOR HYDRAULIC SUBMERSIBLE PUMPS

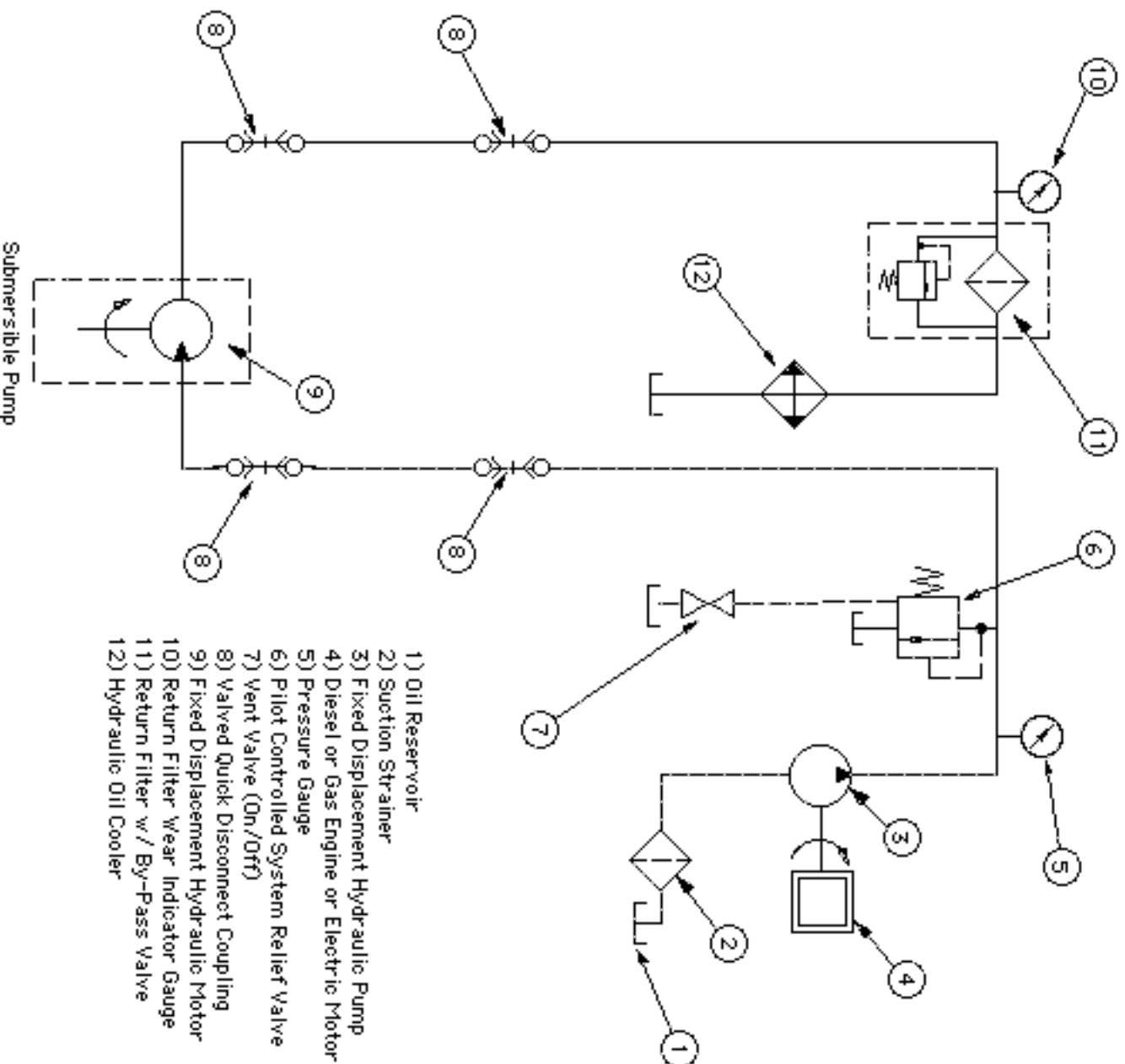

- 1) Oil Reservoir
- 2) Suction Strainer
- 3) Fixed Displacement Hydraulic Pump
- 4) Diesel or Gas Engine or Electric Motor
- 5) Pressure Gauge
- 6) Pilot Controlled System Relief Valve
- 7) Vent Valve (On/Off)
- 8) Valved Quick Disconnect Coupling
- 9) Fixed Displacement Hydraulic Motor
- 10) Return Filter w/ Wear Indicator Gauge
- 11) Return Filter w/ By-Pass Valve
- 12) Hydraulic Oil Cooler