

TYPICAL HYDRAULIC SCHEMATIC
for Engine Driven Power Unit with
Pressure Compensated Hydraulic Pump

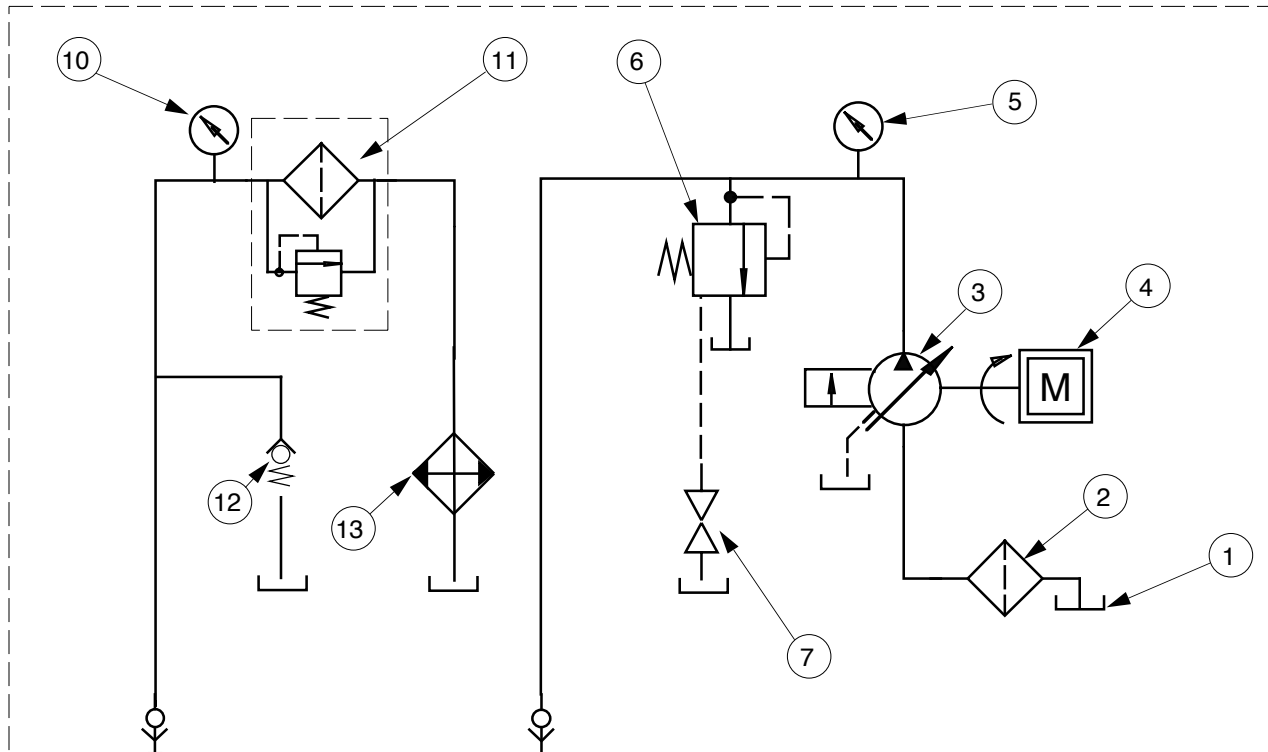

**Hydraulic
Submersible Pump**

- 1) Oil Reservoir
- 2) Suction Strainer
- 3) Pressure Compensated Hydraulic Pump
- 4) Gas or Diesel Engine
- 5) Pressure Gauge
- 6) Pilot Controlled System Relief Valve
- 7) Hydraulic Control Valve (On/Off)
- 8) Valved Quick Disconnect Coupling
- 9) Fixed Displacement Hydraulic Motor
- 10) Return Filter Wear Indicator Gauge
- 11) Return Filter w/ By-Pass Valve
- 12) Cold Oil By-Pass Valve
- 13) Hydraulic Oil Cooler